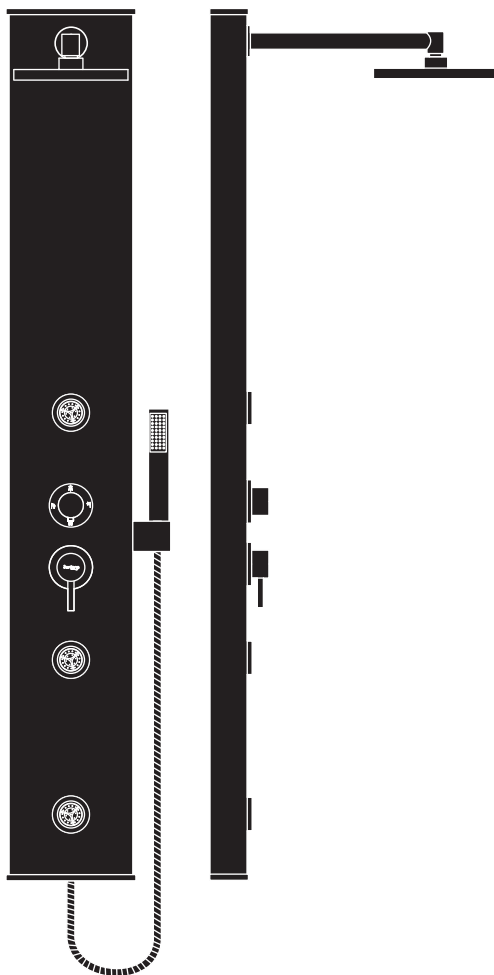


Sanitana



FLEX

coluna de hidromassagem
hydromassage showerpanel
colonne d'hydro massage





ÍNDICE	PT
Introdução	02
Ferramentas necessárias para a instalação	02
Esquema Técnico	03
Pré-Instalação	04
Esquema de pré-Instalação em base de chuveiro	05
Instruções de aplicação em base de chuveiro	06
Instrução de ligações à coluna	07
Guia de utilização	08
Selector de funções e regulador de caudal	08
Jets de hidromassagem	09
Descrição das funções de hidromassagem	10
Manutenção	11
Guia para resolução de problemas	12
Manutenção do cartucho monocomando e do cartucho de funções	13
Assistência técnica	14
Gestão de resíduos	14

TABLE OF CONTENTS	EN
Introduction	16
Materials required for installation	16
Technical plan	17
Pre-installation	18
Shower tray pre-installation diagram	19
Shower tray installation instructions	20
Connection column instructions	21
User guide	22
Function selector and water flow regulator	22
Hydromassage Showerpanel functions	23
Hydromassage jets	24
Maintenance	25
Troubleshooting Guide	26
Maintenance cartridge functions	27
Technical Assistance	28
Waste Management	28

TABLES DE MATIÈRES	FR
Introduction	30
Outils nécessaires	30
Schéma technique	31
Installation	32
Schéma d'installation	33
Instructions d'application dans une base de la douche	34
Instructions de connexion aux colonnes	35
Guide d'utilisation	36
Sélecteur des fonctions et régulateur du débit	36
Description des fonctions d'hydro massage	37
Injecteurs	38
Manutention	39
Guide de dépannage	40
Manutention de la cartouche du débit de la cartouche des fonctions	41
Assistance technique	42
Gestion de déchets	42



INTRODUÇÃO

Agradecemos a confiança e preferência que demonstrou ao eleger um produto de hidromassagem Sanitana. Felicitamos igualmente a sua escolha por um produto especialmente desenvolvido para lhe proporcionar os melhores momentos de prazer e relaxamento.

As colunas de hidromassagem Sanitana são fabricadas tendo uma especial atenção na qualidade dos materiais utilizados. Todas as colunas são testadas à saída das linhas de produção, garantindo que todos os controlos técnicos são observados e ultrapassados.

Nas páginas seguintes encontrará uma descrição completa, assim como recomendações que lhe serão úteis para obter o máximo rendimento na utilização da sua coluna de hidromassagem.

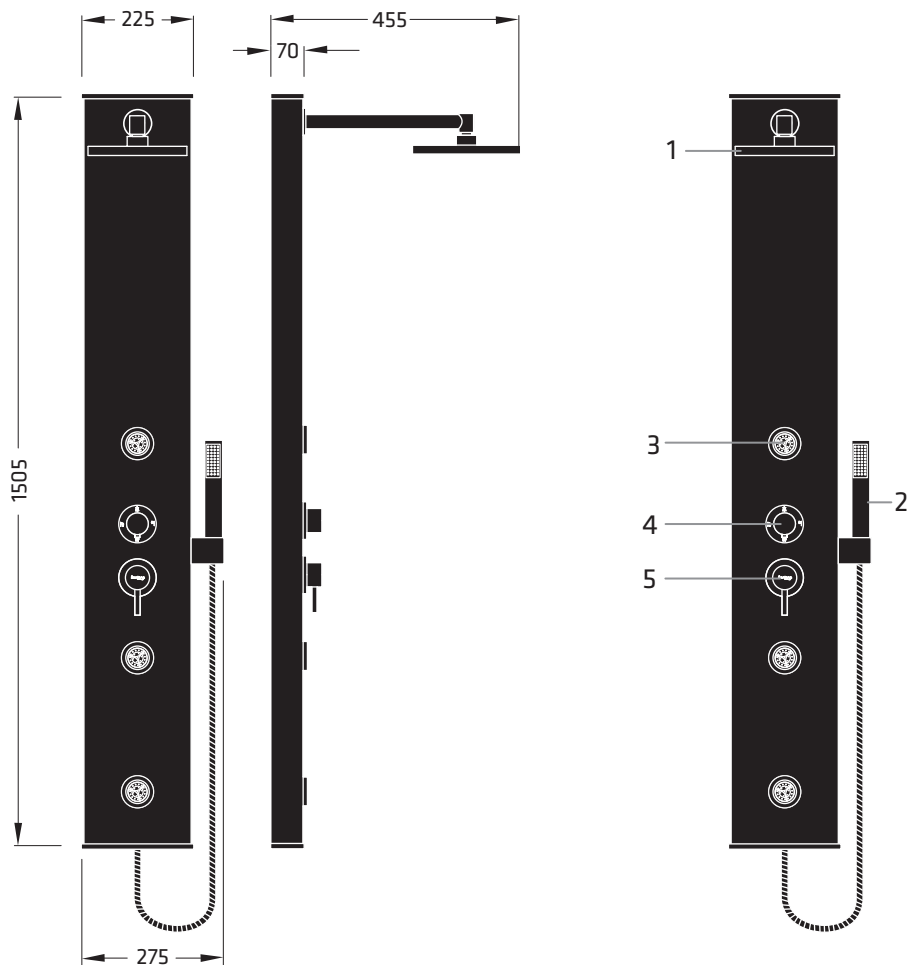
RECOMENDAÇÕES

- A coluna deve manter todas as protecções até final da obra, de modo a evitar possíveis acidentes.
- Para manipular a coluna, pegar-lhe sempre pela armação; nunca deve ser arrastada ou pegada pelas tubagens ou componentes externos; nunca a apoie de pé, mas sim deitada.
- Antes da montagem certifique-se que não houve danos de transporte.

FERRAMENTAS NECESSÁRIAS PARA A INSTALAÇÃO



ESQUEMA TÉCNICO



- 1 - Chuveiro superior (Quadrado/Redondo)
- 2 - Chuveiro de mão (Quadrado/Redondo)
- 3 - Jet de hidromassagem
- 4 - Selector de funções
- 5 - Regulador de caudal





PRÉ-INSTALAÇÃO

- A Instalação deve ser realizada por pessoal qualificado e de acordo com normas vigentes no país;
- Dispor as tomadas de água quente e fria a uma distância aproximada das especificadas (Fig.1);
- É aconselhável colocar torneiras de segurança nestes circuitos de águas;
- Recomenda-se que antes de efectuar a ligação da coluna, se efectue uma limpeza das tubagens da obra deixando correr a água na canalização por algum tempo a fim de evitar posteriores danos provocados por detritos e sujidades acumuladas nas tubagens (Fig.2);

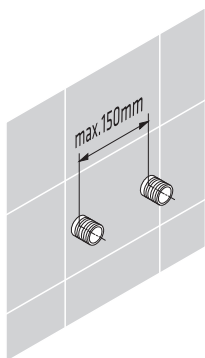


Fig.1

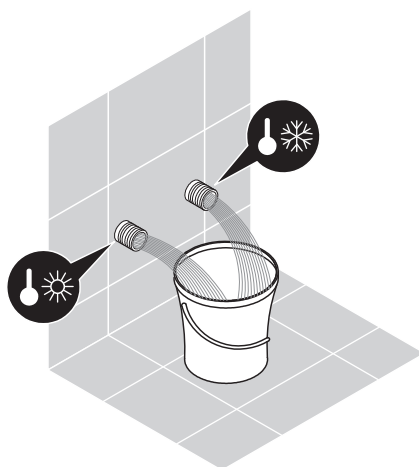


Fig.2

- A pressão da água da rede não deverá ser superior a 5 bar e a temperatura da água quente não deverá ser superior a 55°C. É imperativo que respeite sempre estes limites, pois o incumprimento poderá provocar danos no equipamento. Consulte o seu instalador a este respeito em caso de dúvida;
- A coluna de hidromassagem funciona adequadamente com uma pressão de 2,5 bar. Uma pressão excessivamente baixa ou caudal insuficiente poderá provocar anomalias no seu bom funcionamento e perda dos efeitos de hidromassagem;
- Recomenda-se que a instalação de água quente e fria seja feita por tubagens com 20mm de diâmetro a fim de garantir o adequado caudal para o bom funcionamento dos elementos de hidromassagem;
- As colunas de Hidromassagem estão equipadas com ligações flexíveis em malha de aço, F/F 1/2" e com 700mm de comprimento;

ESQUEMA DE PRÉ-INSTALAÇÃO EM BASE DE CHUVEIRO

MEDIDAS RECOMENDADAS (mm)

A	<1650	1700	1750	1800	1850	1900	1950	2000
B	1850	1900	1950	2000	2050	2100	2150	2200
C	565	615	665	715	765	815	865	915

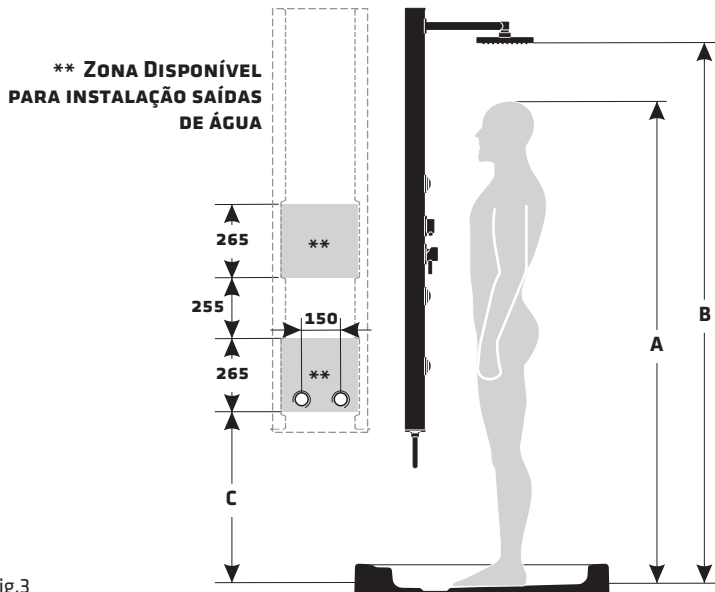


Fig.3

PRESSÃO

MAX. 5 BAR



MIN. 1.5 BAR

RECOMENDADO 3 BAR



TEMPERATURA



MAX.55°C



MIN.30°C



RECOMENDADO 38°C



CARACTERÍSTICAS HIDRÁULICAS

BAR	1.5	3	5
LT/MIN	8	12.5	16.5

INSTRUÇÕES DE APLICAÇÃO EM BASE DE CHUVEIRO

MEDIDAS RECOMENDADAS (mm)

A	<1650	1700	1750	1800	1850	1900	1950	2000
B	1850	1900	1950	2000	2050	2100	2150	2200
D	840	890	940	990	1040	1090	1140	1190

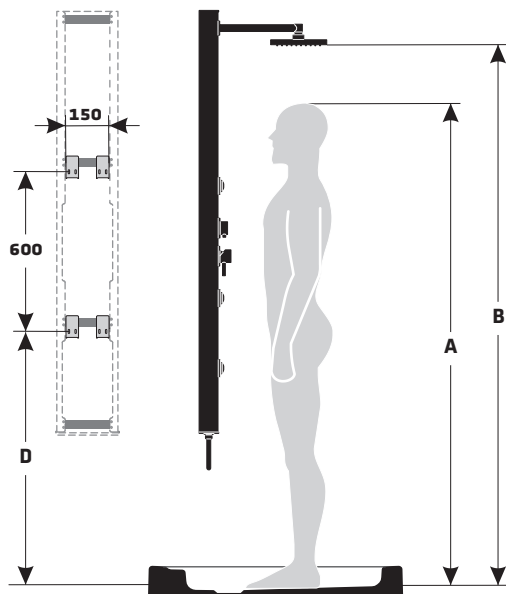


Fig.4

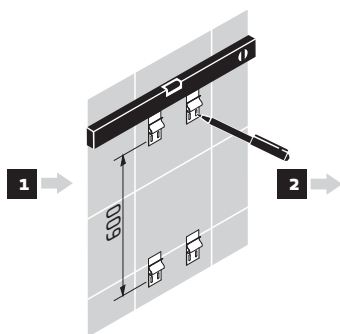


Fig.5

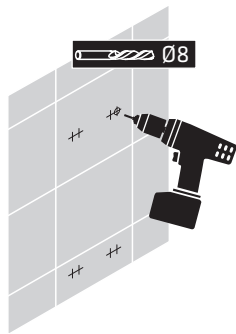


Fig.6

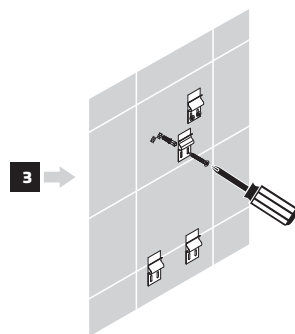


Fig.7

INSTRUÇÃO MONTAGEM LIGAÇÕES

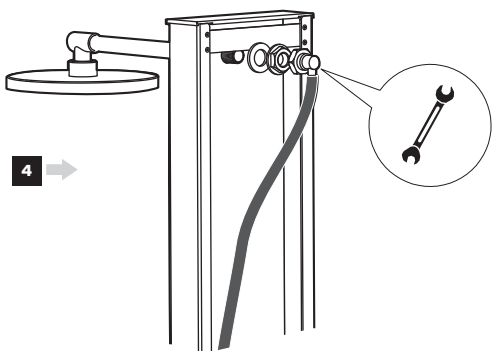


Fig.8

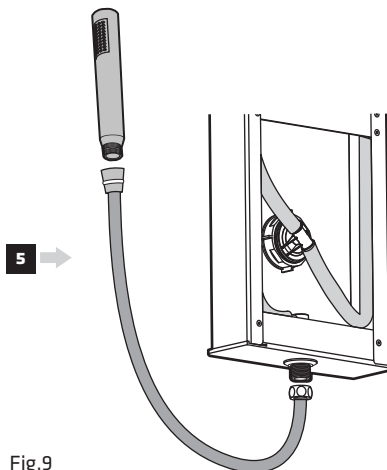


Fig.9

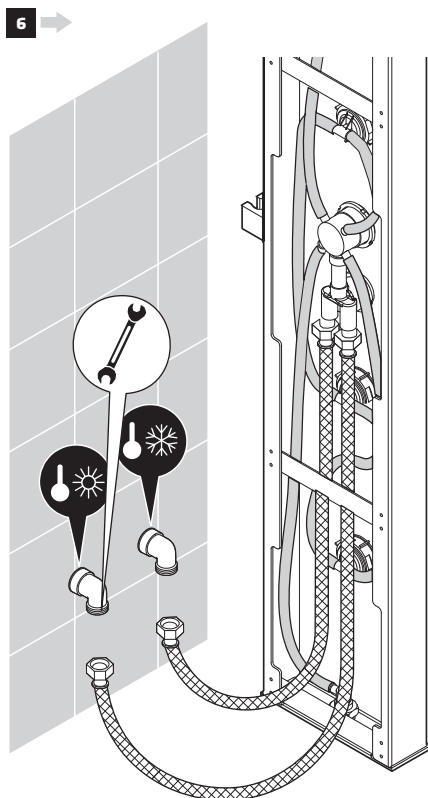


Fig.10

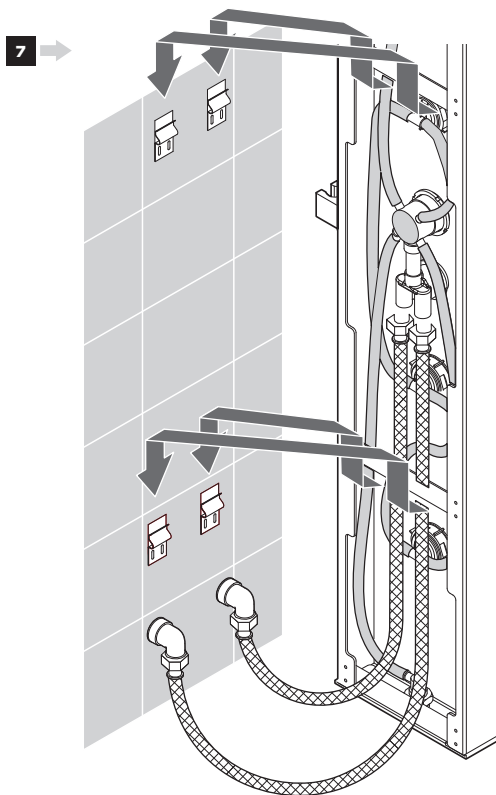


Fig.11



GUIA DE UTILIZAÇÃO

1. Selecione a função desejada no selector de funções.
2. Ajuste a temperatura da água.
3. Abra a torneira reguladora do caudal progressivamente até obter a pressão de hidromassagem que lhe convenha.

SELECTOR DE FUNÇÕES E REGULADOR DE CAUDAL

Ao rodar o manípulo do selector de funções (Fig.12), selecciona cada uma das 4 funções disponíveis:

- a) Chuveiro de mão auxiliar
- b) Chuveiro Superior
- c) Massagem coxas
- d) Massagem dorsal

Estas funções seleccionam-se de forma independente, não sendo recomendado o seu funcionamento em simultâneo, porque tal gera uma perda de eficácia dos efeitos de massagem pretendida.

É possível modificar a função sem por isso necessitar de fechar o abastecimento de água, pode assim passar de uma função à outra sequencialmente sem interrupção.

O comando de abertura, regulação, fecho de caudal e de temperatura, permite igualmente regular a pressão dos jactos de hidromassagem. Este opera como indicado na (Fig.13).

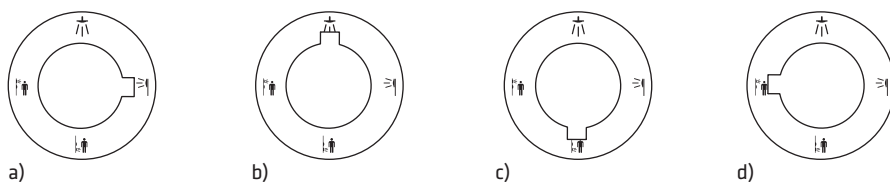


Fig.12

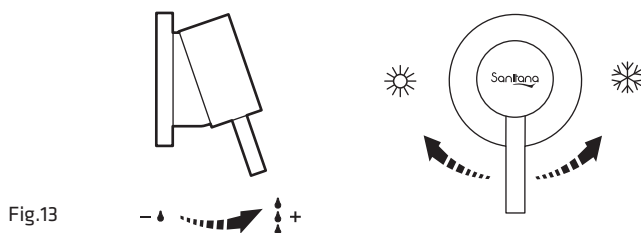


Fig.13

DESCRIÇÃO DAS FUNÇÕES DE HIDROMASSAGEM DA COLUNA

O regulador de temperatura permite através da correcta selecção da temperatura da água diversos tipos de massagem e efeitos terapêuticos:

- Duche Frio: Efeito Revigorante e Energético
- Duche Morno: Efeito Tonicante
- Duche Quente: Efeito Relaxante

Com o prático e cómodo selector de funções poderá seleccionar as diferentes funções de massagem da coluna:

- O chuveiro superior permite gerar uma maior sensação de envolvimento durante o duche.
- O chuveiro de mão auxiliar permite obter o controlo total da direcção do jacto de água, sendo ideal para proporcionar massagens localizadas.
- d) Os jactos de hidromassagem, permitem ao utilizador uma massagem que relaxa e distende os músculos endurecidos.

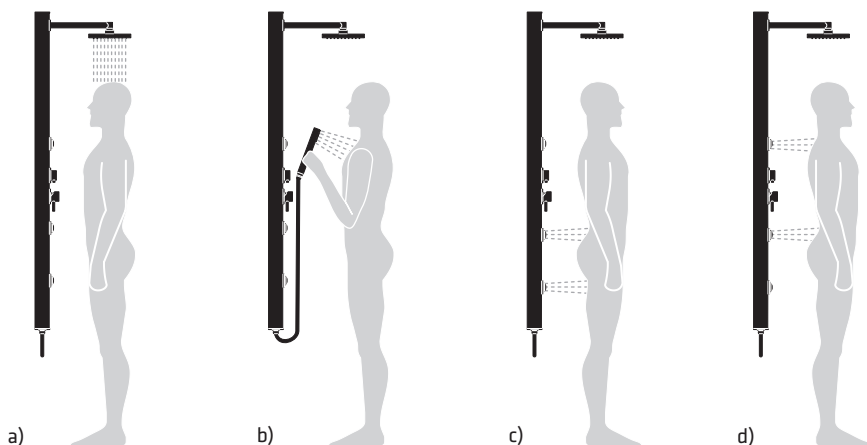
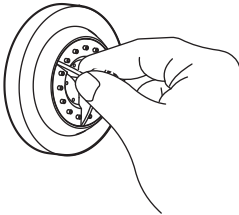


Fig.14

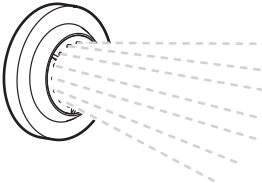
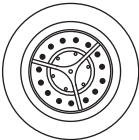
RECOMENDAÇÕES

- É recomendado que o uso da coluna por crianças seja sempre feito sob supervisão de um adulto, por medida de precaução e segurança.
- Recomendamos que a duração do duche de hidromassagem não exceda os 20 minutos.

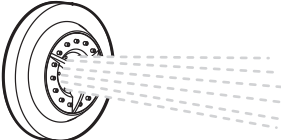
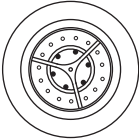
JETS DE HIDROMASSAGEM



FUNÇÃO 1



FUNÇÃO 2



FUNÇÃO 3

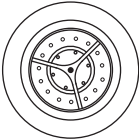


Fig.15

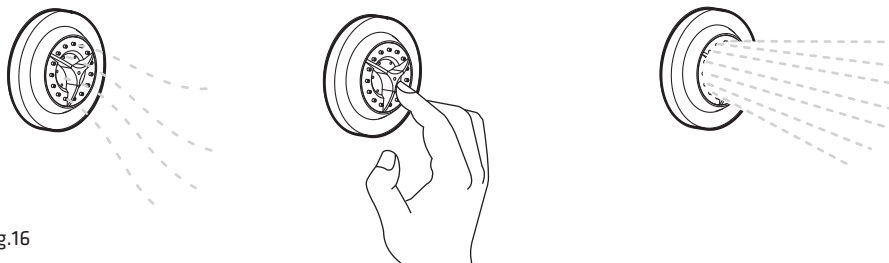
MANUTENÇÃO


Fig.16

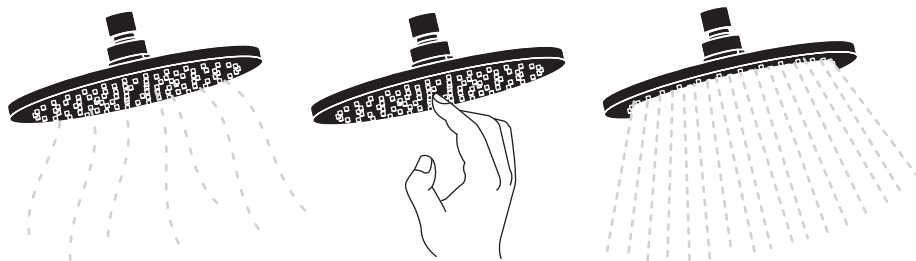


Fig.17

RECOMENDAÇÕES

- Não limpar com produtos ou objectos com propriedades abrasivas, composições químicas agressivas ou amoniacais.
- Evitar todo o tipo de operações com objectos pontiagudos ou metálicos a fim de prevenir qualquer tipo de riscos.



Fig.18



GUIA PARA RESOLUÇÃO DE PROBLEMAS

<p>A COLUNA NÃO TEM PRESSÃO</p>	<p>VERIFIQUE QUE AS BICHAS DE LIGAÇÃO À CANALIZAÇÃO NÃO ESTÃO TORCIDAS OU DOBRADAS (FIG.19)</p>
	<p>VERIFICAR QUE A PRESSÃO DO ESQUENTADOR OU CALDEIRA NÃO É INFERIOR OU SUPERIOR AO RECOMENDADO</p>
	<p>VERIFICAR SE A PRESSÃO DA ÁGUA DA COMPANHIA NÃO É INFERIOR À RECOMENDADA (VER PÁG.05)</p>
	<p>CERTIFICAR-SE QUE FOI EFECTUADA A LIMPEZA DAS TUBAGENS ANTES DE EFECTUAR A LIGAÇÃO E MONTAGEM DA COLUNA (PÁG.06)</p>
<p>A COLUNA VERTE ÁGUA PELO CONJUNTO HIDRÁULICO (REGULADOR DE TEMPERATURA E REGULADOR DE CAUDAL)</p>	<p>VERIFICAR SE A PRESSÃO DA ÁGUA DA COMPANHIA NÃO É SUPERIOR À RECOMENDADA (VER PÁG.05)</p>

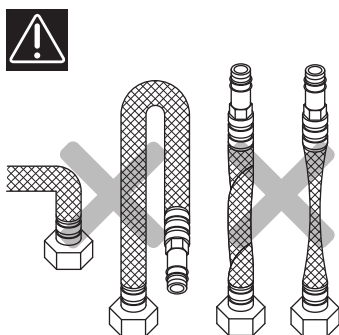


Fig.19

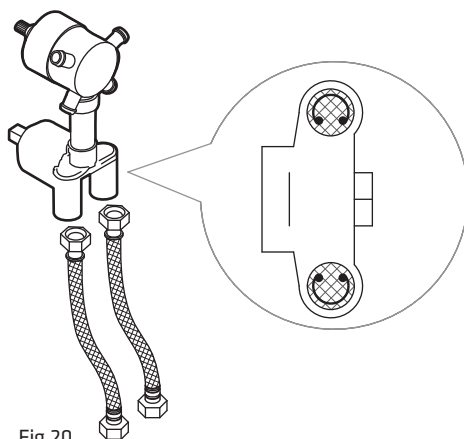


Fig.20

MANUTENÇÃO DO CARTUCHO MONOCOMANDO E DO CARTUCHO DE FUNÇÕES

Os cartuchos das colunas Sanitana são inspecionáveis e substituíveis pela parte frontal da coluna não necessitando assim de remover e desmontar a coluna da parede para substituir estes componentes.

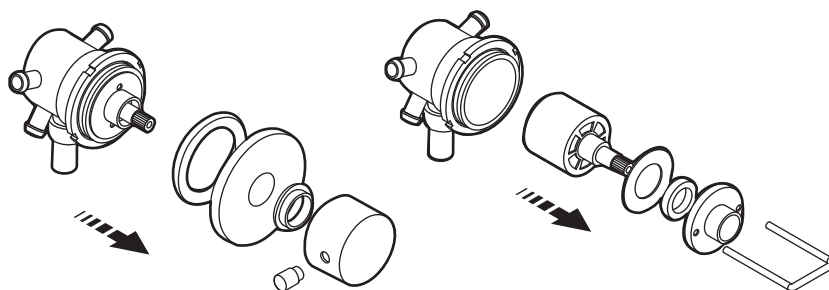
SUBSTITUIÇÃO DO CARTUCHO DE FUNÇÕES

Fig.21

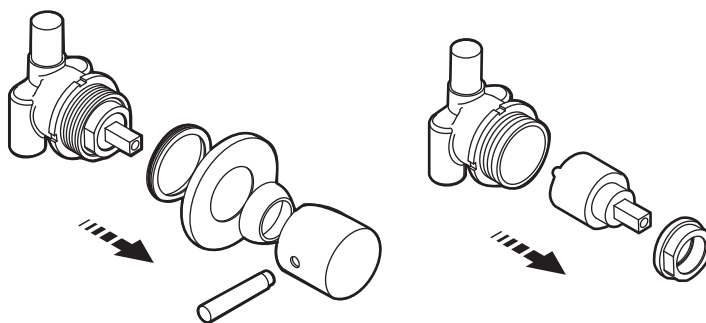
SUBSTITUIÇÃO DO CARTUCHO MONOCOMANDO

Fig.22



SERVIÇO DE ASSISTÊNCIA TÉCNICA

Antes de contactar o Serviço Pós-Venda:

Verificar se não é possível resolver o problema com base nos pontos descritos em “Guia para resolução de problemas”.

Se o problema persistir após essas verificações, contacte o Serviço Pós-Venda da marca. A fim de facilitar o serviço e os nossos técnicos o poderem servir, deverá indicar sempre:

- Uma breve descrição do problema;
- O tipo e o modelo exacto da coluna;

Se for necessário efectuar alguma reparação, contacte o Serviço Pós-Venda da marca (terá a garantia da utilização de peças sobresselentes originais e de uma reparação correcta).

TEL: (+351) 231 519 515

FAX: (+351) 231 519 504

assistencia.sanitana@sanitana.pt

Aconselhamos ainda que não seja efectuada qualquer tipo de assistência, sem que esta seja prestada por técnicos qualificados e/ou assistência técnica oficial.

A inobservância destas instruções pode comprometer a segurança e a qualidade do produto.

GESTÃO DE RESÍDUOS

Deposite as embalagens vazias que continham este produto num ecoponto, separando correctamente os diversos materiais.

No fim de vida deste produto não o abandone em qualquer local nem coloque nos contentores municipais de resíduos domésticos. Encaminhe-o para entidades autorizadas para o receber. Se necessitar de mais informação sobre a entidade a quem entregar, contacte os serviços locais.

Uma grande parte dos materiais utilizados no fabrico deste produto são recicláveis, pelo que poderão vir a fazer parte de novos produtos ou servir como matérias-primas. Depende de si.



INTRODUCTION

We thank you for the trust and preference shown by buying a sanitana hydromassage product. We also congratulate you for having chosen a product which was specially designed to offer you the best moments of pleasure and relaxation.

The Sanitana hydromassage showerpanels are produced regarding the quality of the materials. All showerpanels are tested after the production process, ensuring that all technical controls are concluded with approval.

In the following pages you will find a comprehensive description and also some useful advice in order to enjoy all the functionalities of your showerpanel.

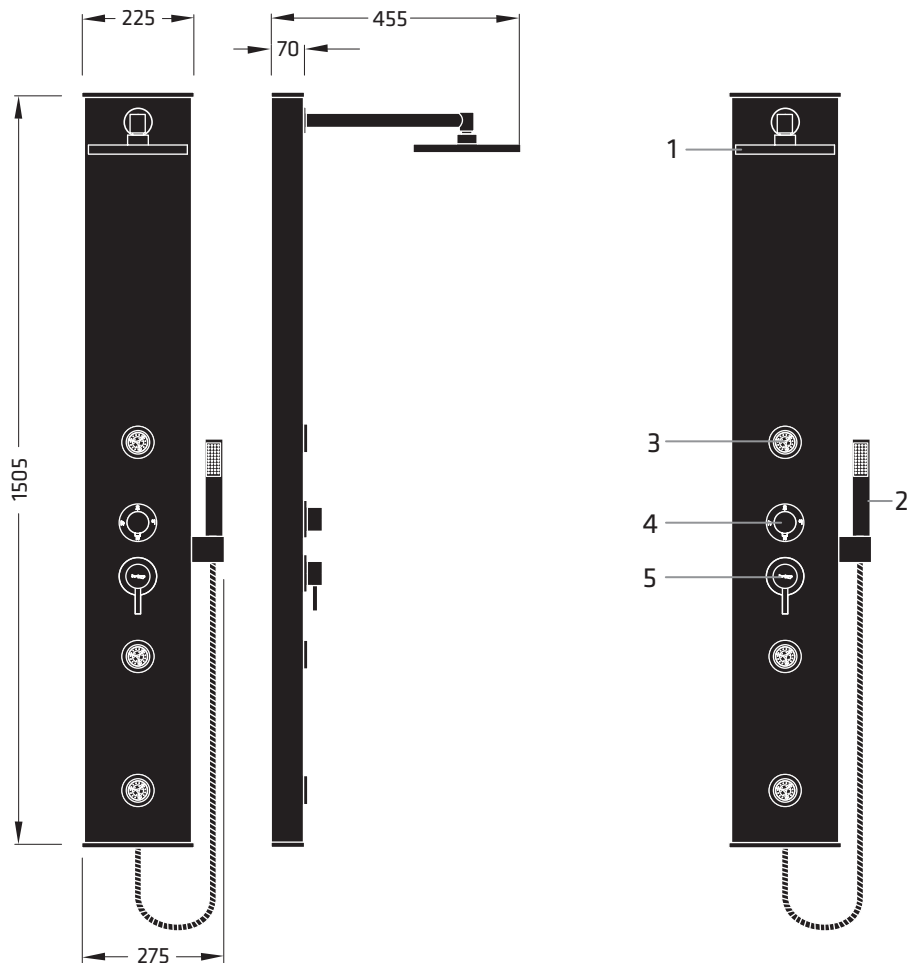
RECOMMENDATIONS

- The showerpanel should maintain all the protective devices until the installation is complete to avoid possible incidents.
- Manipulate by the structure in order to move the showerpanel; it shall never be dragged, or hold through the pipes or external components; it shall be placed horizontally and not vertically.
- Before the installation make sure that no damages were caused during the transportation.

MATERIALS REQUIRED FOR INSTALLATION



TECHNICAL PLAN



- 1 - Upper Shower
- 2 - Hand Shower
- 3 - Hydromassage jets
- 4 - Function selector
- 5 - Temperature regulator





PRE-INSTALLATION

- The installation must be carried out by qualified personnel and in compliance with current local standards;
- Hot and cold water connections should be at an approximate distance as the specified (Fig.1);
- It is advisable to put safety valves in water circuits;
- Before installing the showerpanel, it is advisable to clean and run water in the pipes to avoid subsequent damage caused by waste accumulated in the pipes (Fig.2);

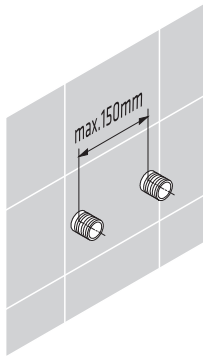


Fig.1

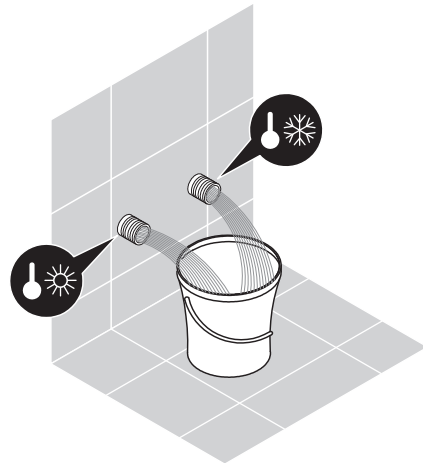


Fig.2

- The pressure of mains water should not exceed 5 bar and hot water temperature should not exceed 55 ° C. It is imperative to always respect those boundaries, because their failure could result in equipment damage;
- The hydromassage column works properly with a pressure of 2.5 bar. An excessively low pressure or inadequate flow may cause malfunction and loss of the hidromassaje effects;
- It is recommended that the installation of hot and cold water piping is made of 20mm diameter to ensure adequate flow for the smooth running of the showerpanel;
- The hydromassage showerpanels have flexible connections with steel mesh F/F 1/2" and 700 mm length.

SHOWER TRAY PRE-INSTALLATION DIAGRAM

RECOMMENDED MEASUREMENTS (mm)

A	<1650	1700	1750	1800	1850	1900	1950	2000
B	1850	1900	1950	2000	2050	2100	2150	2200
C	565	615	665	715	765	815	865	915

**** OUTPUT WATER RECOMMENDED AREA**

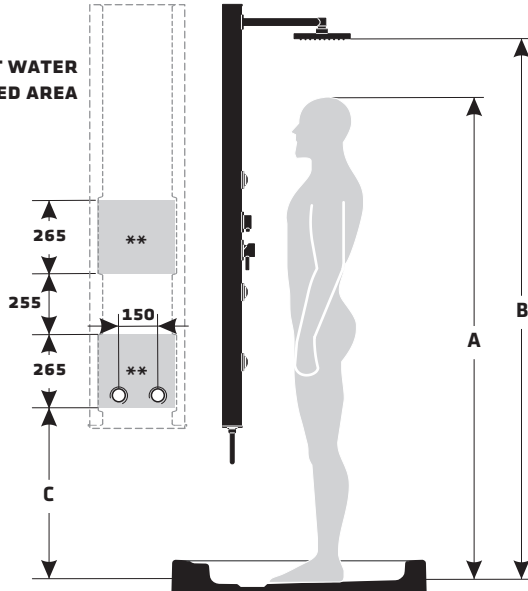


Fig.3

PRESSURE



RECOMMENDED 3 BAR



TEMPERATURE



RECOMMENDED 38°C



HYDRAULIC CHARACTERISTICS

BAR	1.5	3	5
LT/MIN	8	12.5	16.5

SHOWER TRAY INSTALLATION INSTRUCTIONS

RECOMMENDED MEASUREMENTS (mm)

A	<1650	1700	1750	1800	1850	1900	1950	2000
B	1850	1900	1950	2000	2050	2100	2150	2200
D	840	890	940	990	1040	1090	1140	1190

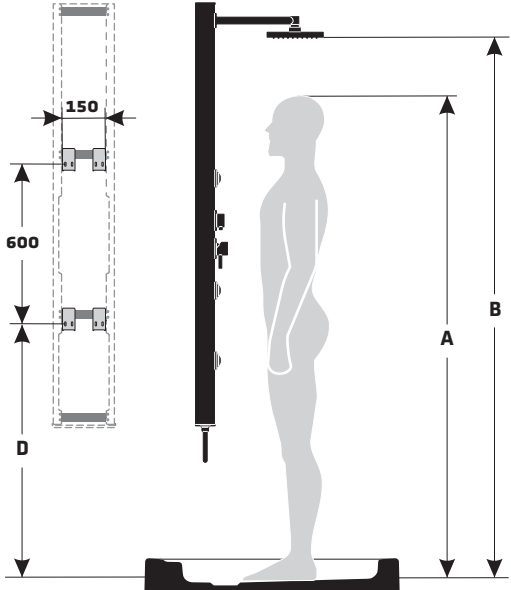


Fig.4

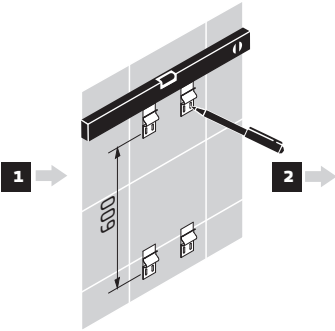


Fig.5

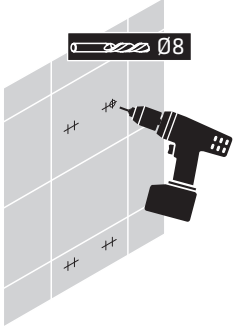


Fig.6

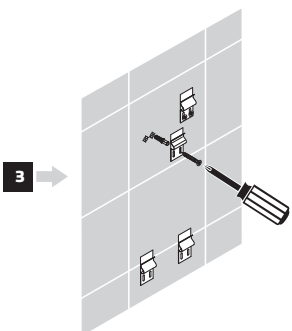


Fig.7

CONNECTION COLUMN INSTRUCTIONS

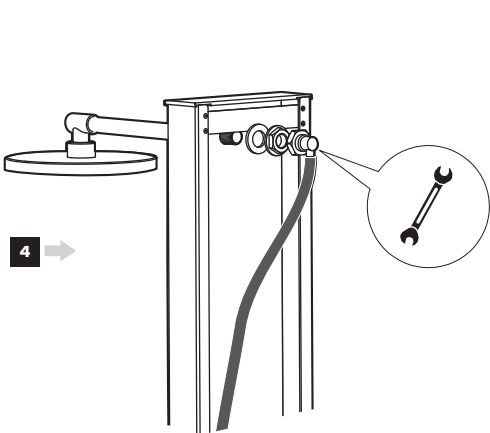


Fig.8

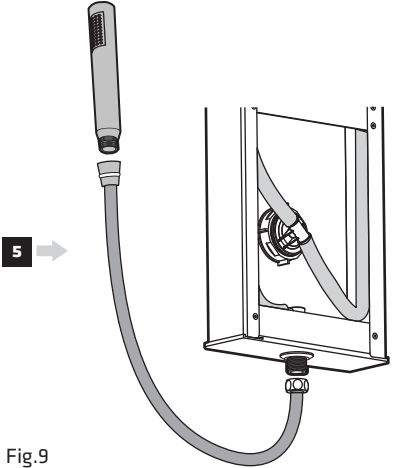


Fig.9

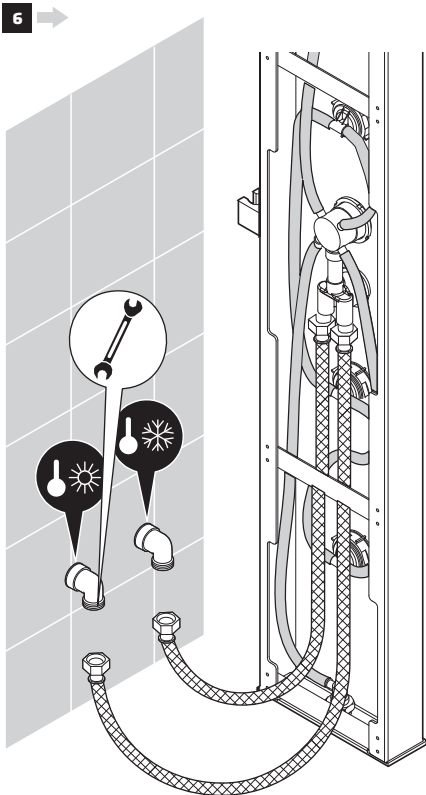


Fig.10

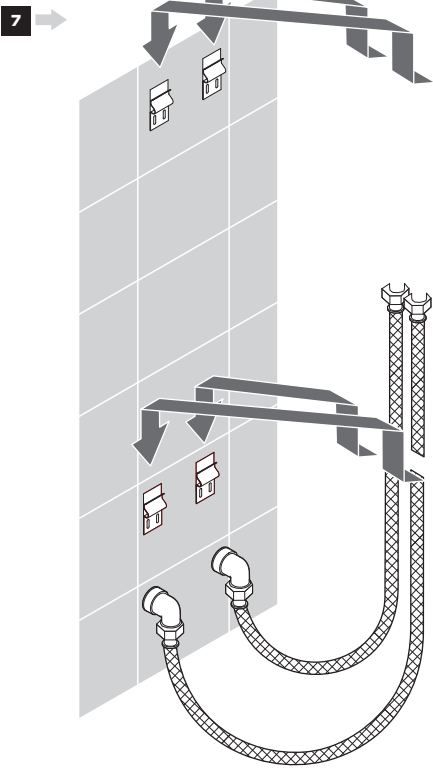


Fig.11



USER GUIDE

1. Select the desired function from the function selector.
2. Adjust the water temperature.
3. Open the water flow regulator tap progressively until you obtain the desired hydromassage pressure.

FUNCTION SELECT AND FLOW REGULATORS

When you turn the diverter handle from the selector functions (Fig.12), you can select each of the 4 following functions:

- a) Hand shower
- b) Upper shower
- c) Legs massage
- d) Dorsal massage

These functions should be selected independently and is not recommended use them simultaneously, because it generates a loss of effectiveness of the massage.

To modify the function there is no need to close the water supply, so you can move from one function to another sequentially without interruption.

The control for temperature, opening and closing of flow regulation, it also allows adjusting the pressure of the hydromassage jets. It operates as shown in (Fig.13).

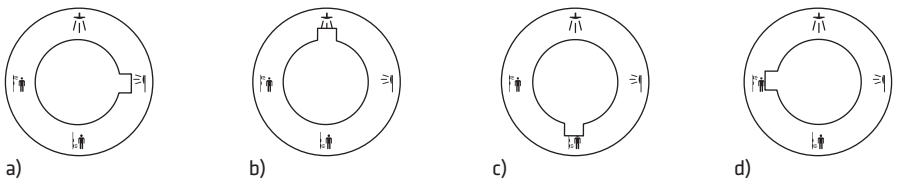


Fig.12

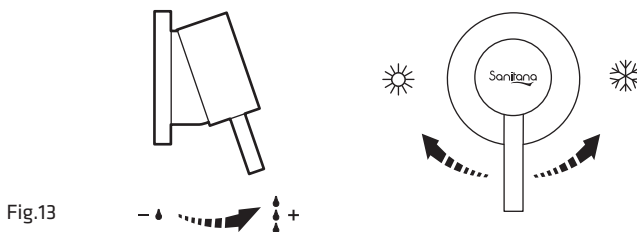


Fig.13

SHOWER PANEL HIDROMASSAGE FUNCTIONS

The temperature control thermostat allows you to produce, through the proper selection of water temperature several types of massage and therapeutic effects:

- Cold Shower: Invigorating and energetic
- Tepid Shower: Tonic effect
- Hot Shower: Relaxing effect

With the 4 function selector you will be able to:

- The upper shower generates a greater surround hydromassage.
- The hand shower allows you full control of the direction of the jet of water, making it ideal for providing localized massages.
- d) The hydromassage jets, will allow you to use a massage that relaxes and stretches the tight muscles.

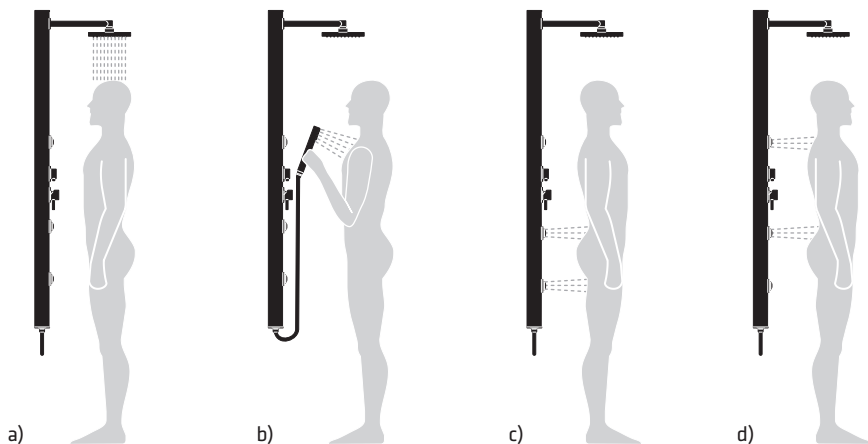


Fig.14

RECOMMENDATIONS

- It is recommended that the column usage by children should always be done under adult supervision, as a precaution and safety

- We recommend that the duration of the massage shower does not exceed 20 minutes



HYDROMASSAGE JETS

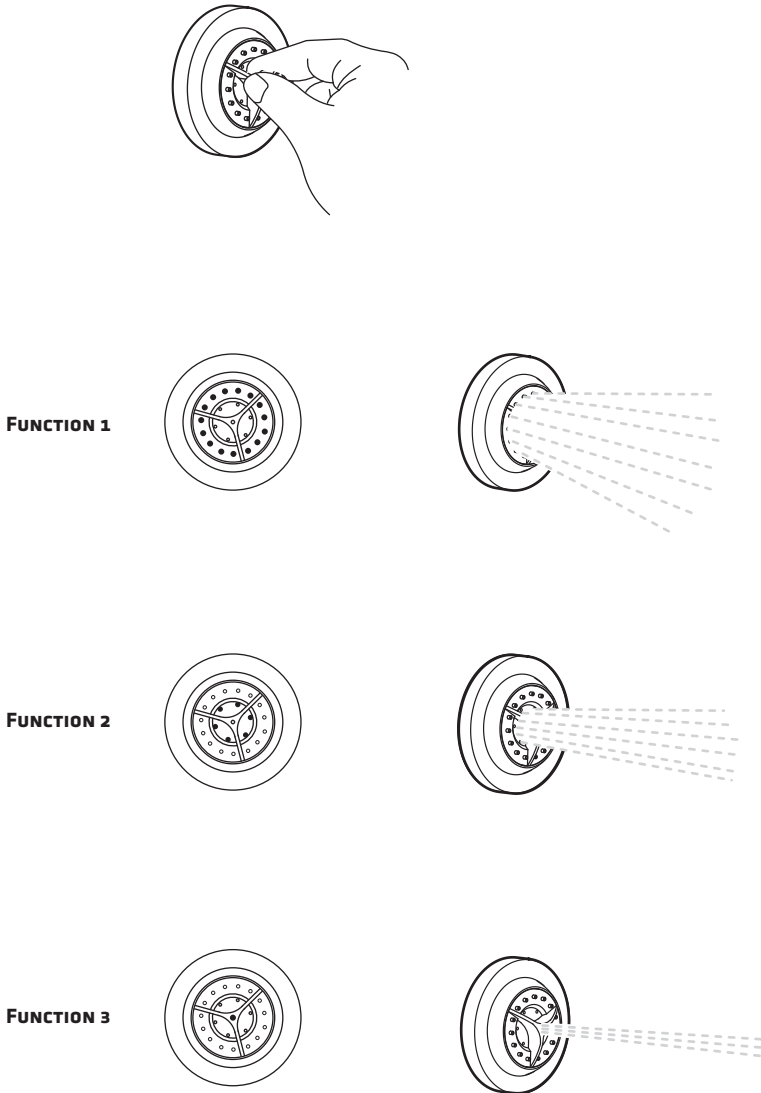


Fig.15

MAINTENANCE

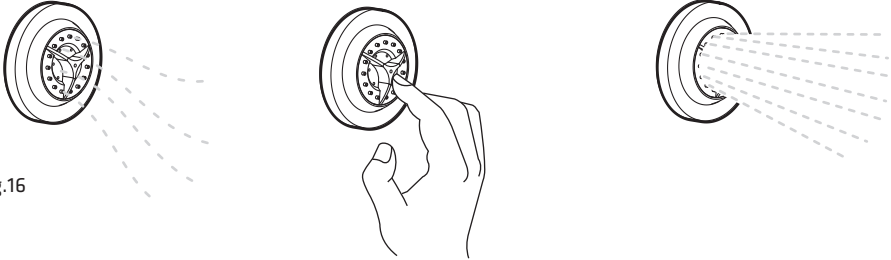


Fig.16

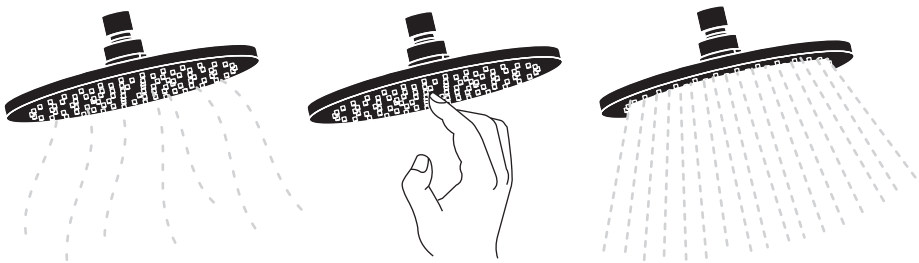


Fig.17

RECOMMENDATIONS

- Do not clean with products or objects with abrasive properties, chemical compositions aggressive or ammonia, it is enough a damp cloth with soap and water.
- Avoid any kind of handling with sharp objects or metal to prevent any risks.



Fig.18



TROUBLESHOOTING GUIDE

THE COLUMN HAS NO PRESSURE	MAKE SURE IF THE FLEXIBLE CONNECTIONS TO THE PIPES ARE NOT TWISTED OR FOLDED (FIG.19)
	CHECK IF THE PRESSURE OF WATER HEATER IS NOT ABOVE OR BELOW THE RECOMMENDED (PAGE 18)
	CHECK THAT THE MAINS WATER PRESSURE IS NOT LOWER THAN RECOMMENDED
	MAKE SURE IT WAS DONE THE CLEANING PIPES BEFORE CONNECTING AND MOUNTING THE COLUMN (PAGE 18)
	CHECK THE FILTERS AND CHECK VALVES OF THE HYDRAULIC ASSEMBLY OF THE COLUMN (FIG.20)
THE COLUMN AT SHEDDING WATER HYDRAULIC ASSEMBLY (TEMPERATURE REGULATOR AND FLOW CONTROLLER)	CHECK THAT THE MAINS WATER PRESSURE IS NOT HIGHER THAN RECOMMENDED (PAGE 18)

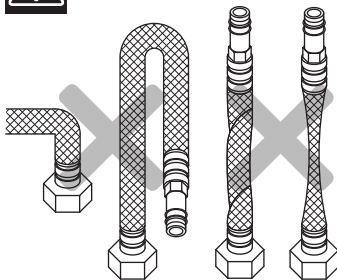


Fig.19

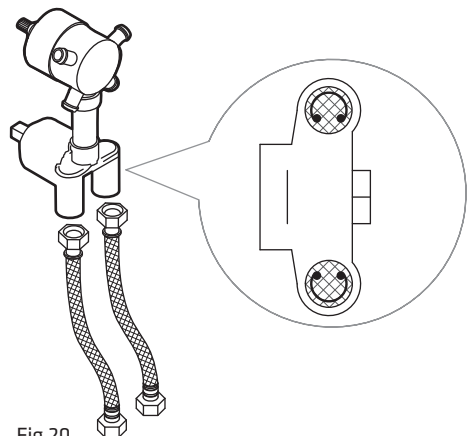


Fig.20

MAINTENANCE CARTRIDGE FUNCTIONS

The cartridges of Sanitana's shower panels can be checked and replaced from the front. Therefore there is no need to remove the shower panel off the wall to repair these components.

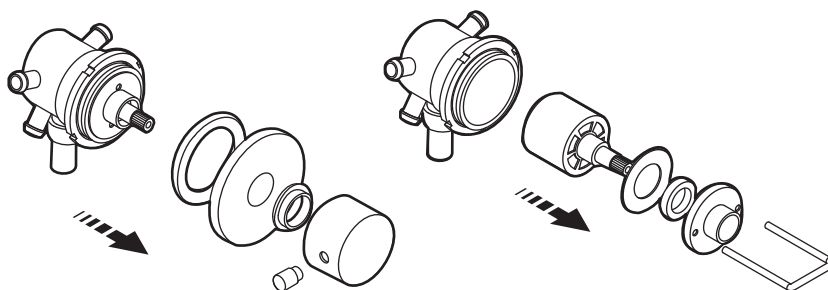
THE CARTRIDGE FUNCTIONS REPLACEMENT

Fig.21

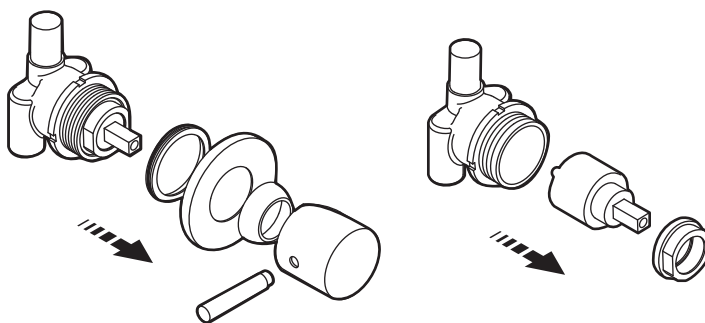
THE CARTRIDGE FLOW CONTROLLER AND TEMPERATURE REGULATION REPLACEMENT

Fig.22



COSTUMER SERVICE

Before contacting costumer service:

Check if you cant solve the problem based on the points outlined in "Troubleshooting Guide".

If the problem persists after these checks, contact the After Sales Service of the brand.

In order to make easier the technical assistance:

- A brief description of the problem;
- The correct model of the column;

If you need to make any repairs, contact the After Sales Service of the brand (you will be assured of the use of original spare parts and a correct repair).

TEL: (+351) 231 519 515

FAX: (+351) 231 519 504

assistencia.sanitana@sanitana.pt

We also recommend not to make out any kind of assistance, that is not provided by qualified and / or official technicians.

Failure to follow these instructions may compromise safety and product quality.

WASTE MANAGEMENT

Put the empty packaging containing this product in a recycling bin, by correctly separating the diverse materials.

When the product is of no use anymore, do not throw it away nor put it in the city domestic garbage bins. Send it to the authorized entities.

If you need any further information on the entity to deliver it to, contact the local services.

Most of the materials used to produce this product are recyclable, so they may be part of other new products or be used as raw materials. It's up to you.



INTRODUCTION

Nous vous remercions de la confiance et de votre préférence en achetant un produit d'hydro massage Sanitana. Nous vous félicitons aussi votre choix par un produit spécialement développé pour vous pouvoir proportionner les meilleurs moments de plaisir et de relâchement.

Les colonnes d'hydro massage Sanitana sont fabriquées en tenant spéciale attention dans la qualité des matériaux utilisés. Toutes les colonnes sont testées à l'issue de nos lignes de production, pour assurer que tous les contrôles techniques sont observés et dépassés.

Dans les pages suivantes vous verrez une description complète, aussi que des recommandations qui vous serez utiles pour obtenir le maximum de rentabilité dans l'utilisation de votre colonne d'hydro massage.

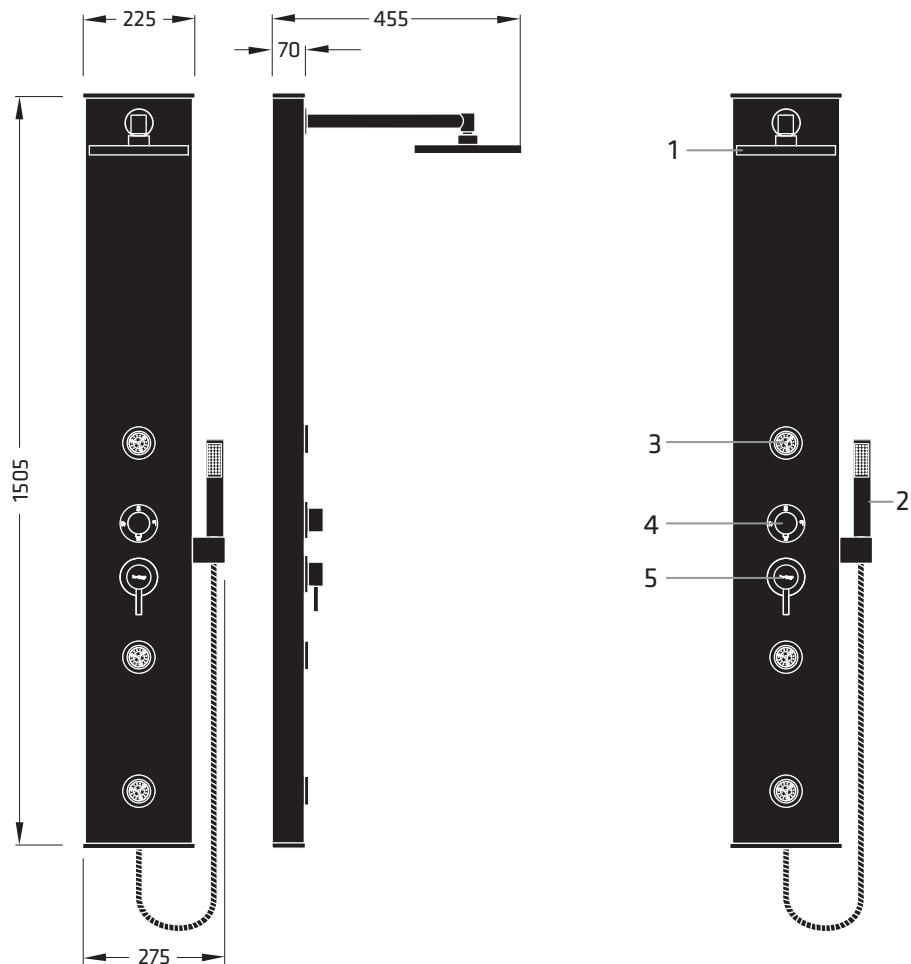
AVERTISSEMENTS

- La colonne doit rester avec toutes les protections jusqu'au final de l'œuvre, pour éviter des accidents.
- Pour manipuler la colonne, vous devez la prendre par l'armature ; ne jamais la traîner ou la prendre par les tuyaux ou par ses composants externes ; ne jamais appuyer debout, seulement couché.
- Avant le montage il faut se certifier qu'il n'a pas eu des dommages dans le transport.

OUTILLAGE NÉCESSAIRE



SCHÉMA TECHNIQUE



- 1 - Douche supérieure
- 2 - Douche de main auxiliaire
- 3 - Injecteurs
- 4 - Sélecteur de fonctions
- 5 - Régulateur du débit et régulateur de la température de l'eau





INSTALLATION

- L'installation doit être fait par du personnel qualifié et conformément les règles en vigueur dans votre pays;
- Disposer les prises de l'eau chaude et de l'eau froide à une distance pareille des de la figure 1;
- Il est tout conseillé de mettre des robinets d'arrêt dans ces circuits d'eau;
- Il est recommandable avant de mettre en circuit la colonne, d'effectuer le nettoyage des tuyaux en laissant l'eau couler dans la canalisation, pendant quelques minutes à fin d'éviter des problèmes provoqués pour des déchets et des saletés accumulés dans les circuits (fig.2);

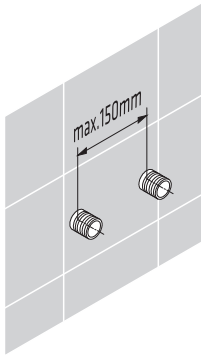


Fig.1

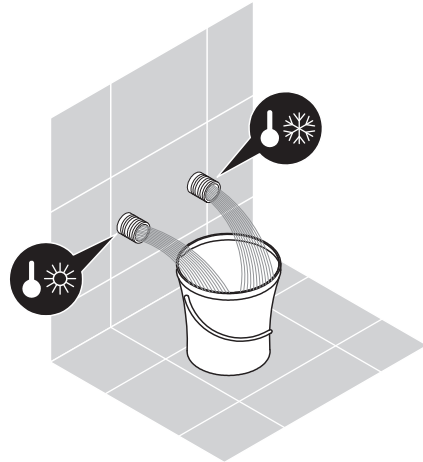


Fig.2

- La pression de l'eau du réseau ne devra dépasser les 5 bars et la température de l'eau chaude ne devra dépasser les 55 degrés. Il faut respecter toujours ces limites, cas contraire il peut provoquer des dysfonctionnements dans votre équipement. Consultez votre installateur à ce respect en cas de doutes;
- La colonne d'hydro massage fonctionne convenablement avec une pression d'eau de 2,5 bars. Une pression excessivement basse ou un débit insuffisant pourra provoquer des anomalies de bon fonctionnement et perte des effets de l'hydro massage;
- Il est recommandable que l'installation de l'eau chaude et froide soit faite en tuyaux avec 20 mm de diamètre à fin de garantir le débit correcte pour le bon fonctionnement des éléments de l'hydro massage;
- Les colonnes d'hydro massage sont équipées avec des bouchons de liaison flexibles en maille d'acier, F/F 1/2 et avec 700 mm de longueur.

SCHEMA D'INSTALLATION DANS UNE BASE A DOUCHE

MESURES RECOMMANDEE (mm)

A	<1650	1700	1750	1800	1850	1900	1950	2000
B	1850	1900	1950	2000	2050	2100	2150	2200
C	565	615	665	715	765	815	865	915

**** ZONE POUR APPLIQUER DES SORTIES DE L'EAU**

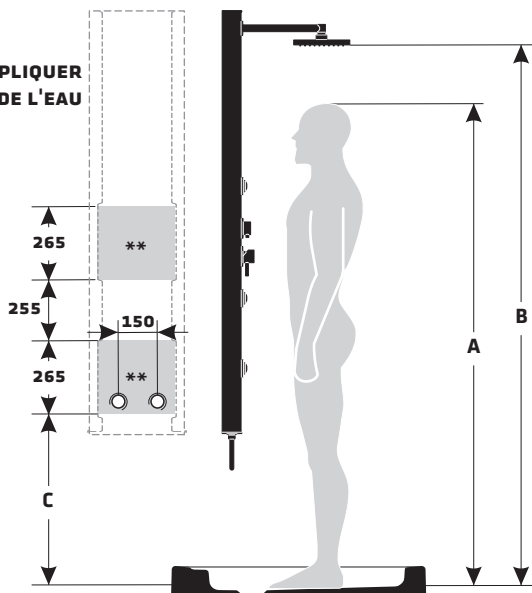


Fig.3

PRESSION

MAX. 5 BAR



MIN. 1.5 BAR

RECOMMANDEE 3 BAR



TEMPERATURE

MAX. 55°C



MIN. 30°C

RECOMMANDEE 38°C



CARACTERISTIQUES HYDRAULIQUES

BAR	1.5	3	5
LT/MIN	8	12.5	16.5

SCHEMA D'INSTALLATION DANS UNE BASE À DOUCHE
MESURES RECOMMANDÉE (mm)

A	<1650	1700	1750	1800	1850	1900	1950	2000
B	1850	1900	1950	2000	2050	2100	2150	2200
D	840	890	940	990	1040	1090	1140	1190

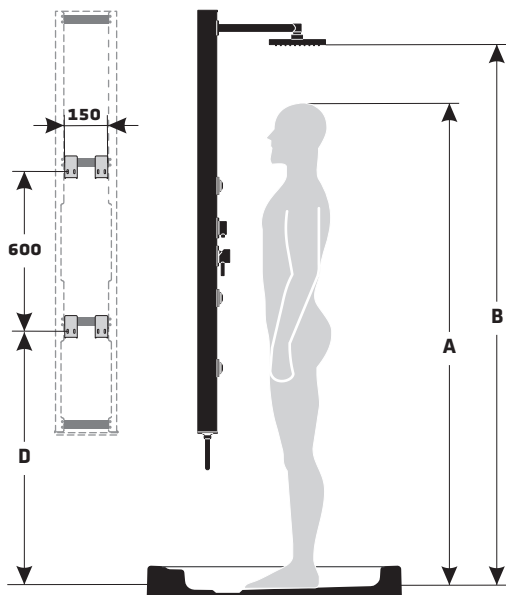


Fig.4

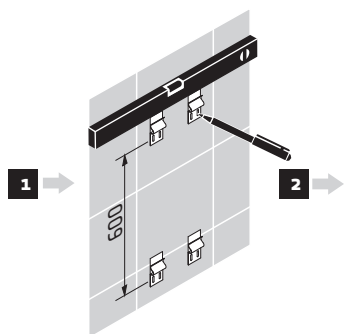


Fig.5

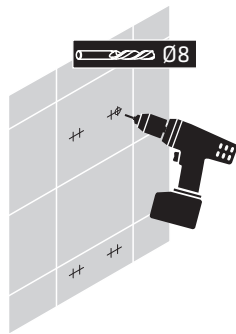


Fig.6

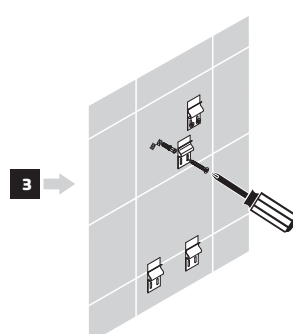


Fig.7

INSTRUCTIONS DE CONNEXION

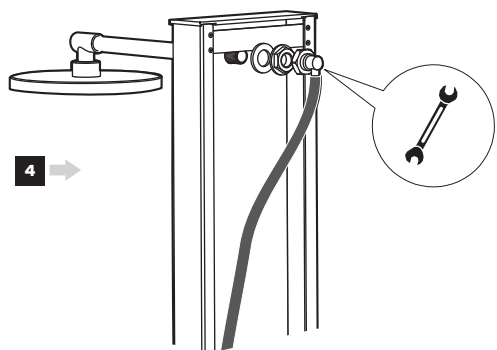


Fig.8

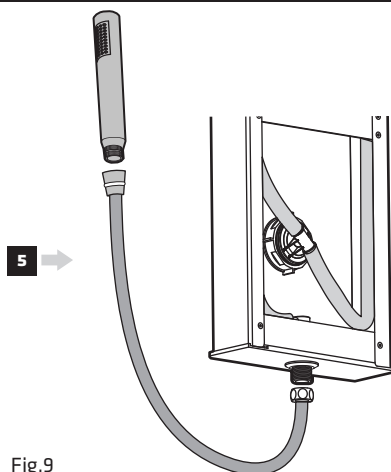


Fig.9

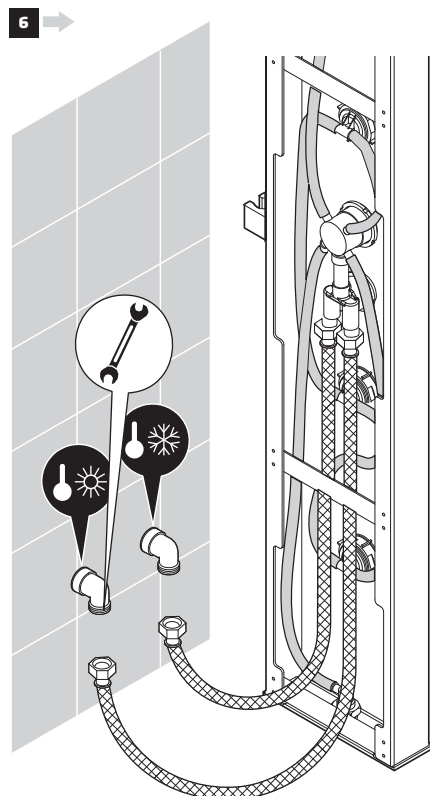


Fig.10

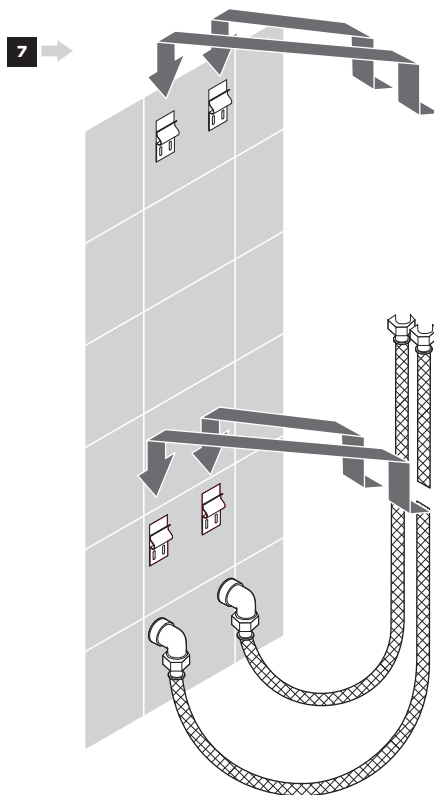


Fig.11



GUIDE D'UTILISATION

1. Sélectionnez la fonction désirée dans le sélecteur de fonctions.
2. Réglez la température de l'eau.
3. Ouvrez le robinet régulateur du débit progressivement jusqu'à obtenir une pression d'hydro massage désirée.

SELECTEUR DES FONCTIONS ET REGULATEUR DU DÉBIT

Quand vous tournez le maniple du sélecteur des fonctions (fig.12), vous pouvez sélectionner une des 4 fonctions disponibles :

- a) Douche de main auxiliaire
- b) Douche supérieur
- c) Massage cuisses
- d) Massage dorsale

Ces fonctions se sélectionnent indépendamment, mais n'est pas recommandable le fonctionnement en simultané, parce que provoque une perte et l'efficacité des effets de massage désirés.

Il est possible modifier la fonction sans fermer la distribution d'eau, alors vous pouvez changer d'une fonction à l'autre séquentiellement sans interrompre.

La commande d'ouverture, régulation, fermeture du débit et de la température, permet également réguler la pression des jets de l'hydro massage. Ce fonctionne comme indiqué dans la (fig.13).

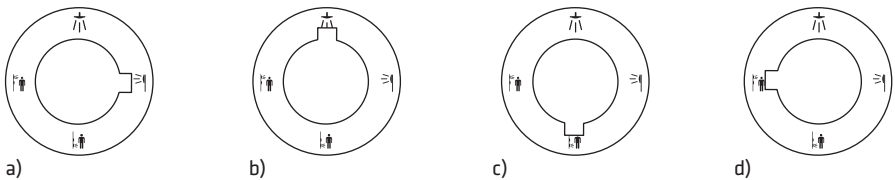


Fig.12

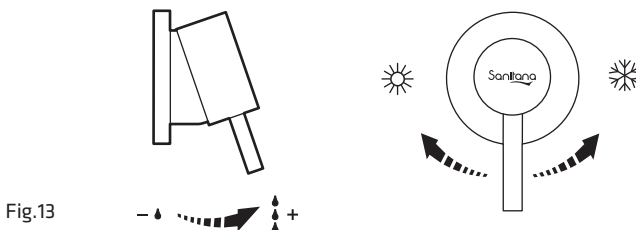


Fig.13

DESCRIPTION DES FONCTIONS D'HYDRO MASSAGE DE LA COLONNE

Le régleur de température permet, à travers d'une correcte sélection de la température de l'eau, sélectionner des divers types de massage et des effets thérapeutiques :

- Douche froide : résultat revigorant et énergétique
- Douche tiède : résultat tonifiant
- Douche chaude : résultat relâchant

Avec le pratique et commode sélecteur de fonctions vous pouvez sélectionner les différents fonctions de massage de la colonne:

- La douche plafonnier permet avoir une plus grande sensation d'enveloppement pendant la douche.
- La douche à main permet avoir le contrôle total de la direction du jet de l'eau, étant idéal pour faire des massages localisés.
- d) Les jets d'hydro massage, permettent à l'utilisateur un massage relâchant pour détendre les muscles endurcis.

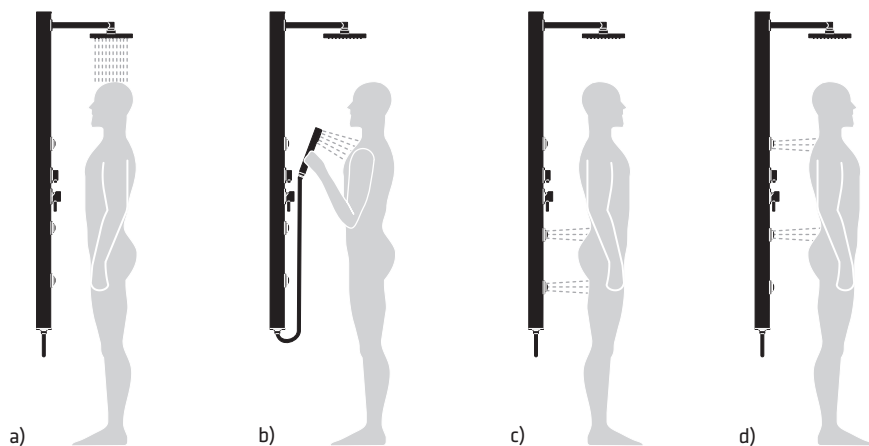


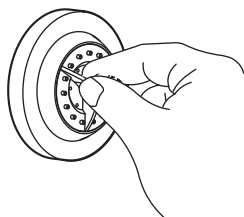
Fig.14

AVERTISSEMENTS

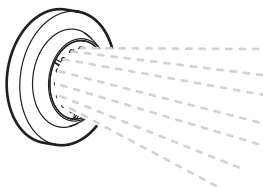
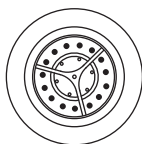
- Il est conseillé que l'usage de la cabine par des enfants soit toujours faite avec la surveillance d'un adulte, à fin d'éviter des accidents et pour des questions de sécurité.
- La durée totale de la douche ne doit idéalement pas dépasser 20 minutes.



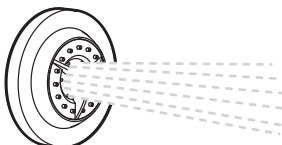
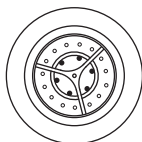
INJECTEURS



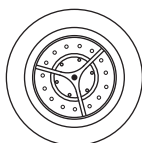
FONCTION 1



FONCTION 2



FONCTION 3



MANUTENTION

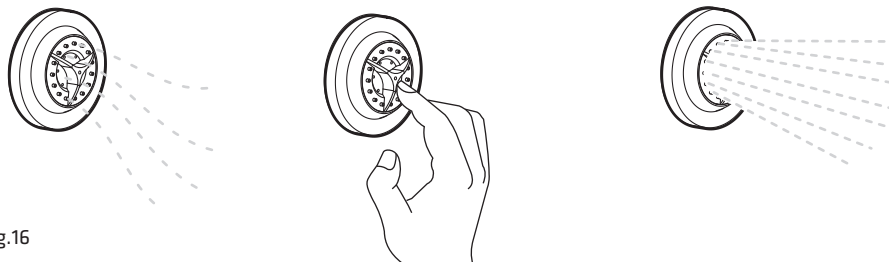


Fig.16

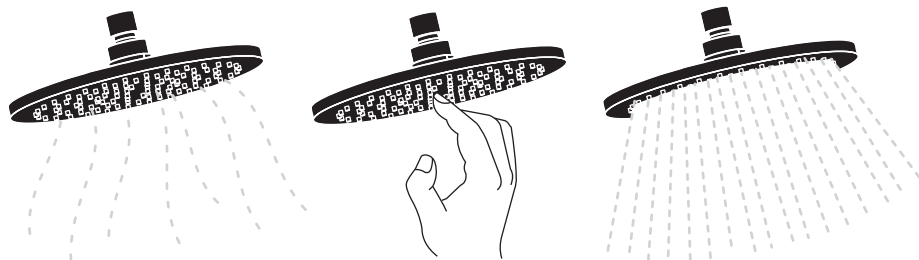


Fig.17

AVERTISSEMENTS

- Ne nettoyez pas avec des produits ou des objets abrasifs, avec des compositions chimiques agressives ni des ammoniacaux.
- Éviter tous les types d'opérations avec des objets pointus ou métalliques à fin d'éviter des traits.



Fig.18



GUIDE DE DEPANNAGE

LA COLONNE N'A PAS DE PRESSION	VÉRIFIEZ SI LES CÂBLES DE LIAISON AUX CONDUITES NE SONT PAS TORTUS OU DOUBLÉS (FIG.19)
	VÉRIFIEZ SI LA PRESSION DU CHAUFFE BAIN OU DE LA CHAUDIÈRE N'EST PAS INFÉRIEUR OU SUPÉRIEUR AU RECOMMANDÉ
	VÉRIFIEZ SI LA PRESSION DE L'EAU DU RÉSEAU N'EST PAS INFÉRIEURE AU RECOMMANDÉ (VOIR PAG. 32)
	SE CERTIFIER QU'IL A ÉTÉ FAIT LE NETTOYAGE DES TUYAUX AVANT D'EFFECTUER LA LIAISON ET LE MONTAGE DE LA COLONNE (VOIR PAG. 32)
	VÉRIFIEZ SI LES FILTRES DU CONJOINT HYDRAULIQUE DE LA COLONNE NE SONT PAS OBSTRUÉS (FIG.20)
LA COLONNE VERSE DE L'EAU POUR LE CONJOINT HYDRAULIQUE (RÉGULATEUR DE LA TEMPÉRATURE ET RÉGULATEUR DU DÉBIT)	VÉRIFIEZ SI LA PRESSION DU RÉSEAU N'EST PAS SUPÉRIEUR À LA RECOMMANDÉE (VOIR PAG. 32)

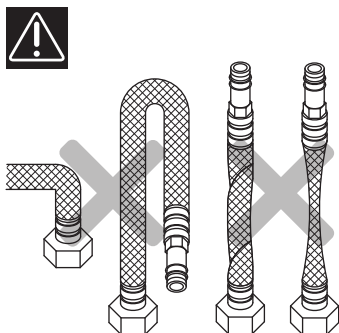


Fig.19

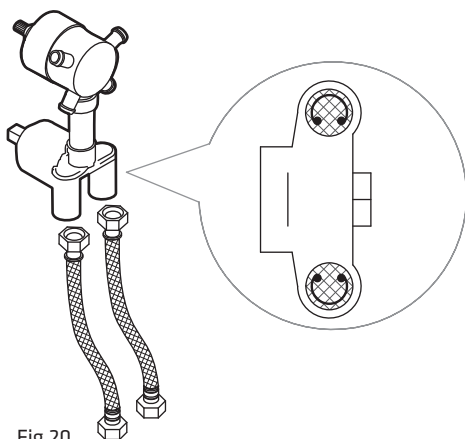


Fig.20

MANUTENTION DE LA CARTOUCHE DU DÉBIT ET DE LA CARTOUCHE DES FONCTIONS

Il est possible d'examiner et substituer les cartouches Sanitana, à travers du front de la cabine, alors il ne faut pas retirer ni démonté la colonne du mur pour assister ces composants.

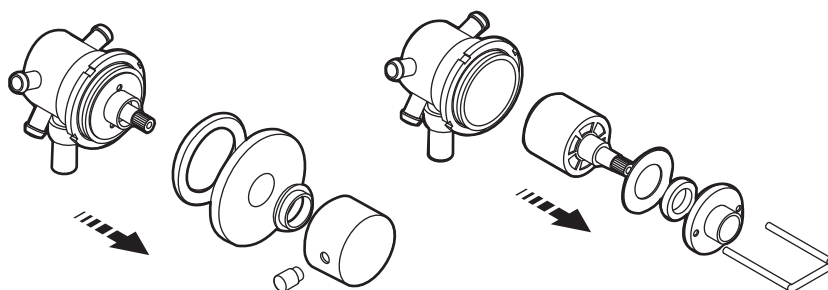
SUBSTITUTION DE LA CARTOUCHE DES FONCTIONS

Fig.21

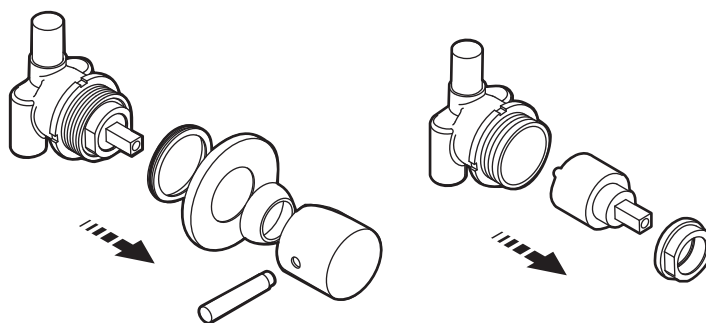
SUBSTITUTION DE LA CARTOUCHE DU DÉBIT ET DU RÉGLEUR DE LA TEMPÉRATURE

Fig.22



SERVICE D'ASSISTANCE TECHNIQUE

Avant de contacter le service d'assistance :

Vérifier s'il est possible de résoudre le problème avec le guide de dépannage.

Si le problème persiste après ces vérifications, contactez le service post-vente.

À fin de faciliter le service et le travail de nos techniciens vous devrez indiquer toujours :

- Une brève description du problème
- Le type et le modèle de votre colonne

S'il faut une réparation, contactez notre service post-vente de la marque (vous auriez la garantie de l'utilisation de pièces de rechange originales et d'une réparation correcte.)

Phone: (+351) 231 519 515

Fax: (+351) 231 519 504

assistencia.sanitana@sanitana.pt

Nous vous conseillons encore de ne pas faire quelque type d'assistance, sauf s'elle était faite par des techniciens qualifiés et/ou par une assistance technique officielle.

L'inaccomplissement de ces instructions peut compromettre la sécurité et la qualité de ce produit.

GESTION DE DÉCHETS

Mettez les emballages vides de ce produit dans une collecte sélective, en séparant correctement les divers matériaux.

En fin de vie de ce produit il ne doit pas être traité comme des déchets ménagers. Il doit être remis à un point de collecte approprié pour le recyclage.

Pour toute information supplémentaire à ce sujet, vous pouvez contacter votre municipalité.

Une grande partie des matériaux utilisés dans la fabrication de ce produit sont recyclables, alors ils pourront faire partis de nouveaux produits ou utilisés comme matière première. Ça dépend à vous.

SANITANA FÁBRICA DE SANITÁRIOS DE ANADIA, S.A.

ZONA INDUSTRIAL DE ANADIA

APARTADO 45 | 3781-909 ANADIA (PORTUGAL)

T: 231 519 500 | F: 231 511 024

info@sanitana.com

www.sanitana.com

www.facebook.com/sanitana

ASSISTÊNCIA TÉCNICA

T: 231 519 515 | F: 231 519 504

assistencia.sanitana@sanitana.pt