

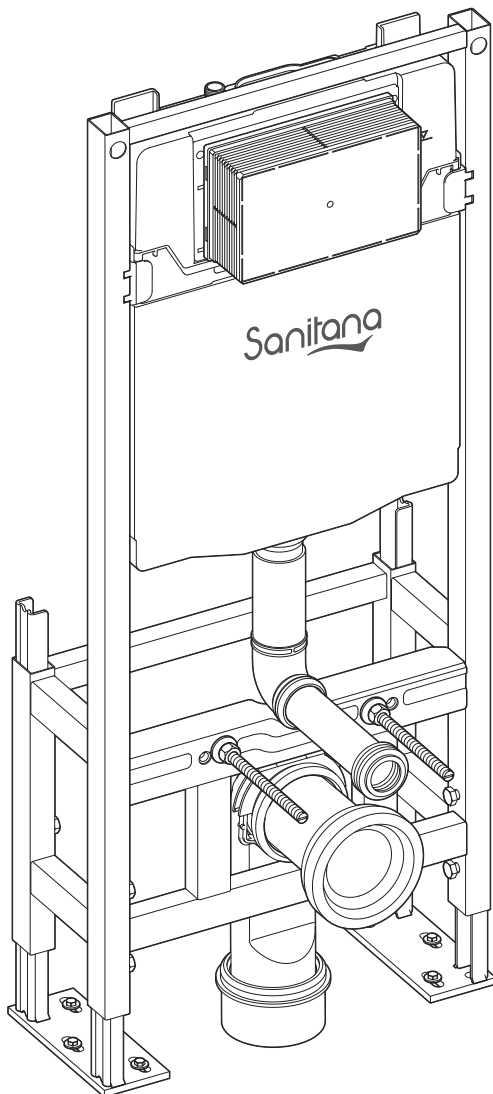

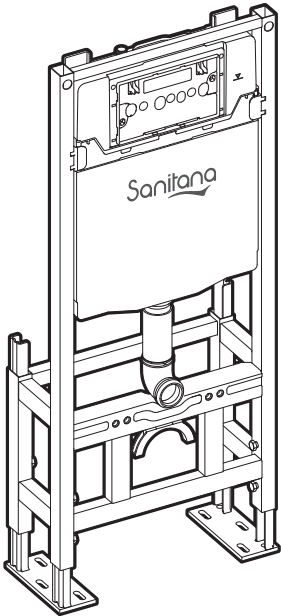

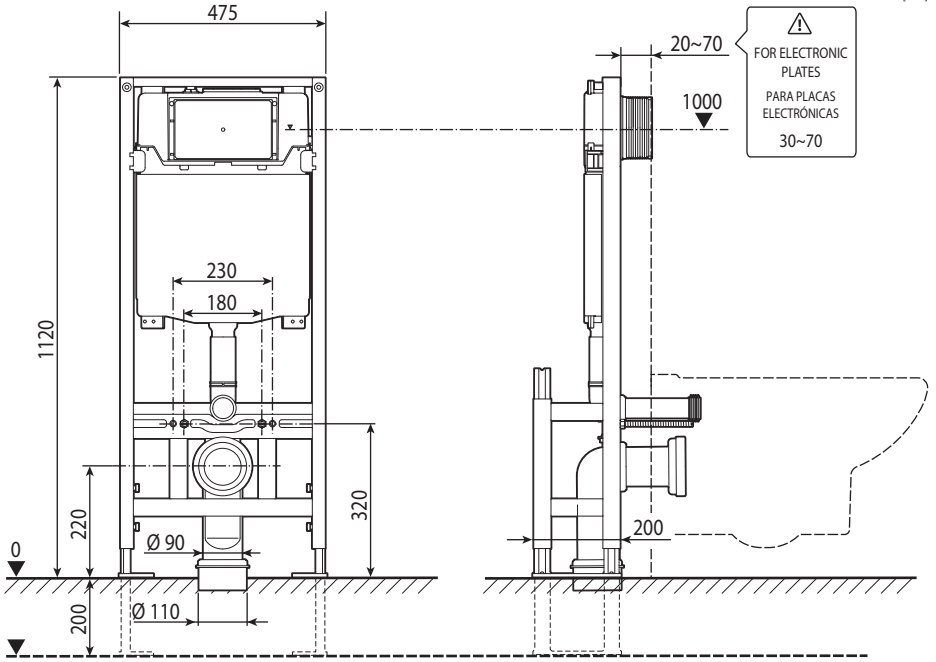





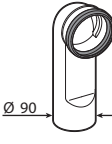



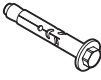

Sanitana



SI0200779300000





 $\varnothing 90$ x1	 $\varnothing 110$ x1	 x1	 x1
	 x1	 x6	 x6
 x1	 x1	 x1	 x1
 x2	 x2	 x4	 x4
		 x2	 x2

1

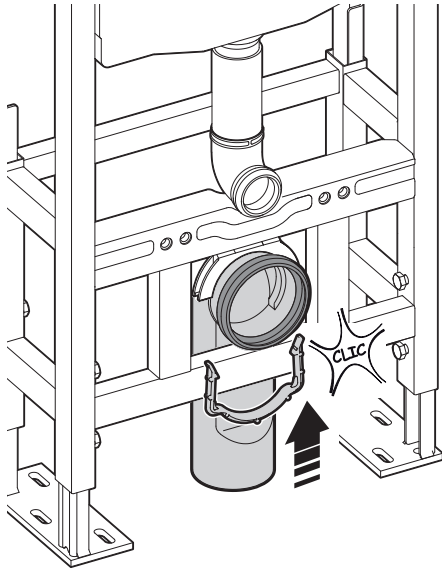

2

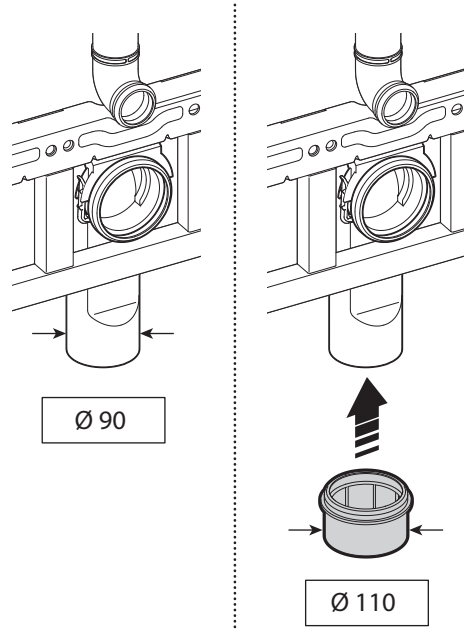

3

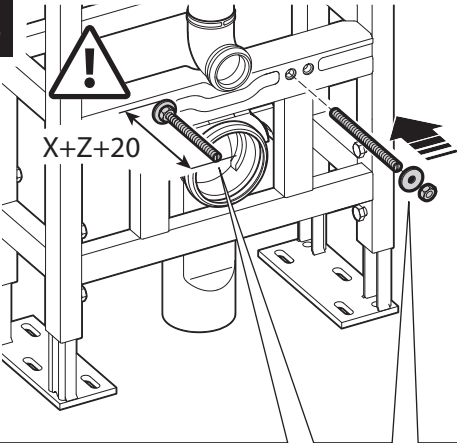

4

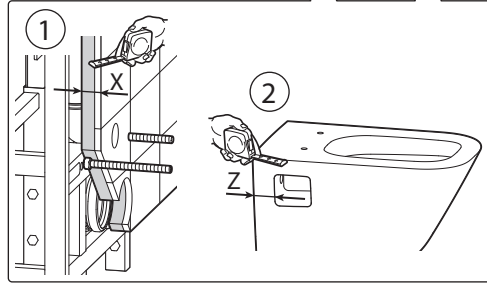
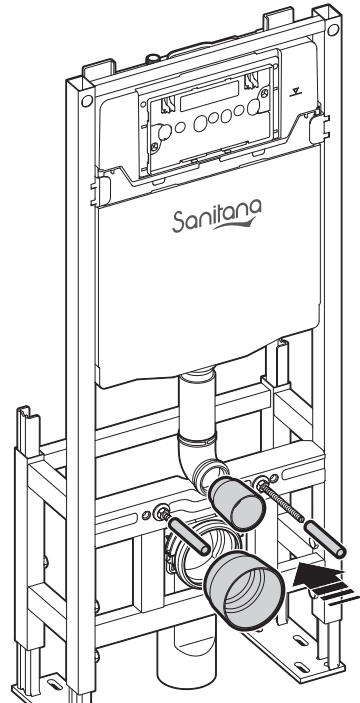



5

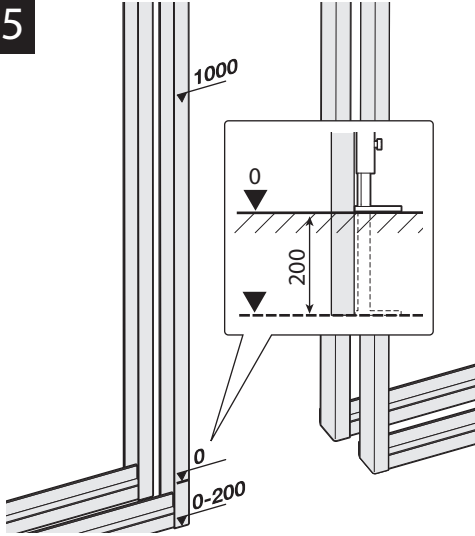

6

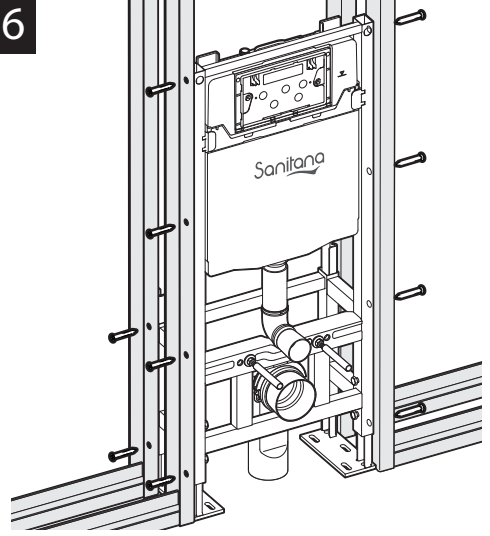

5

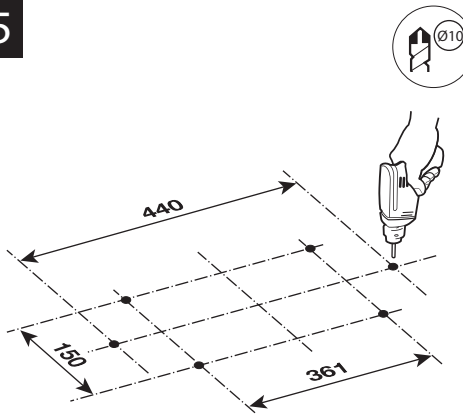

6

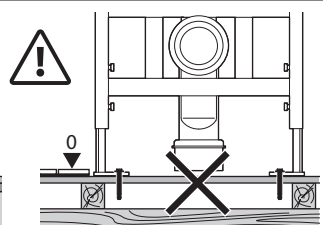
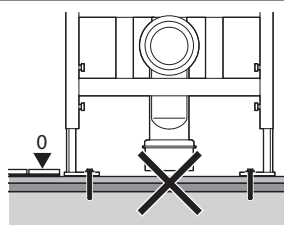
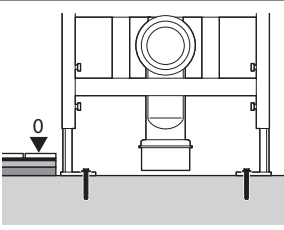
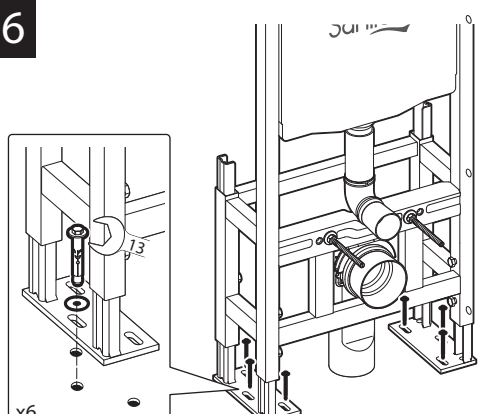

7

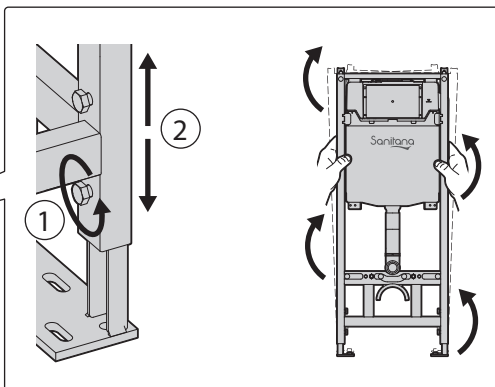
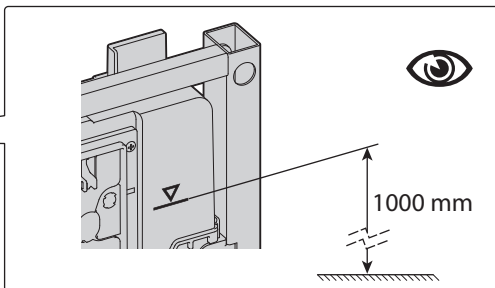
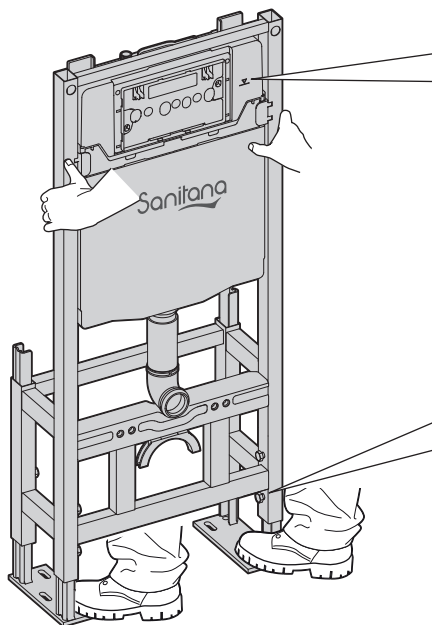

8

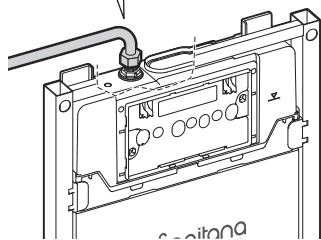
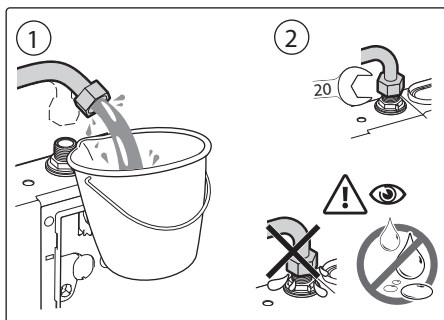

9

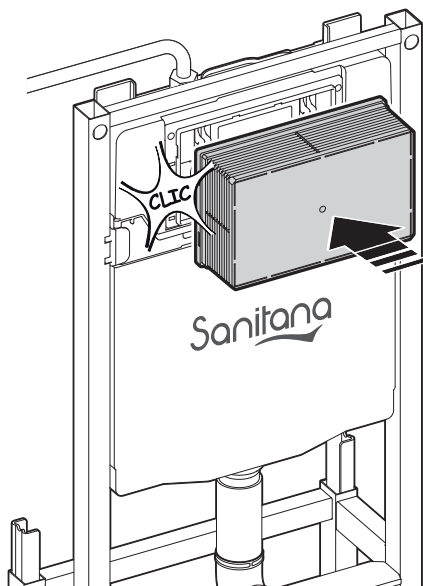

P
bar



10

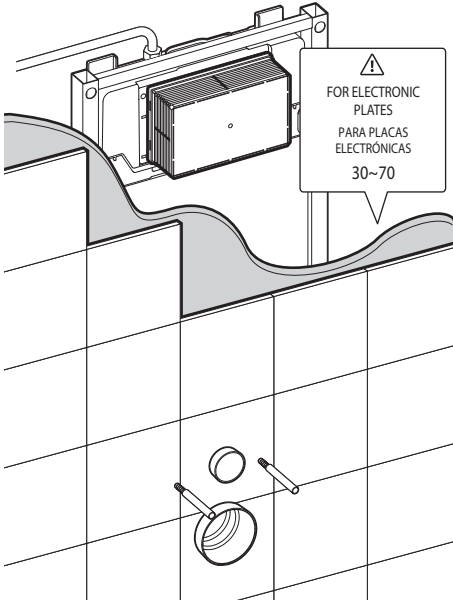

11

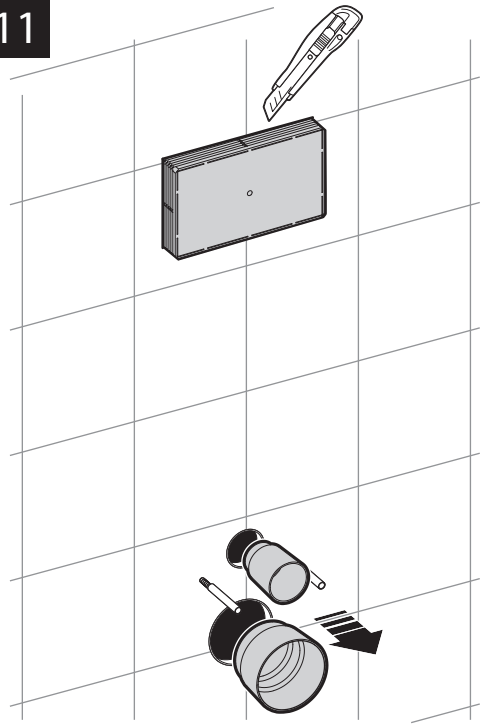

1

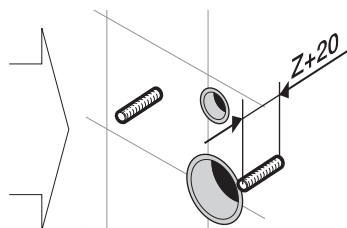
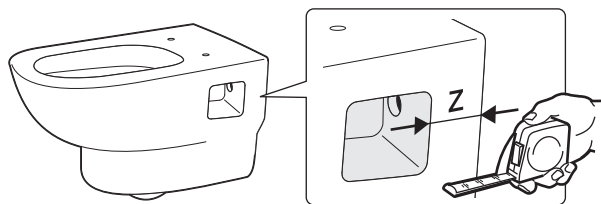

2

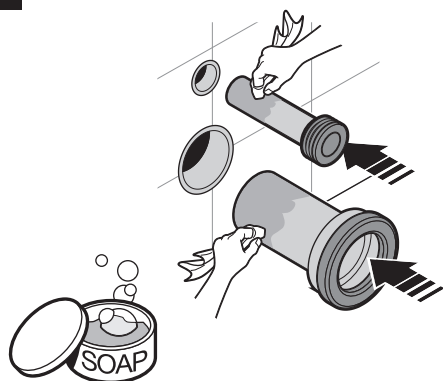

3

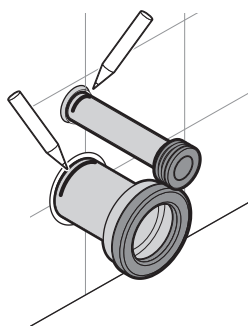

4

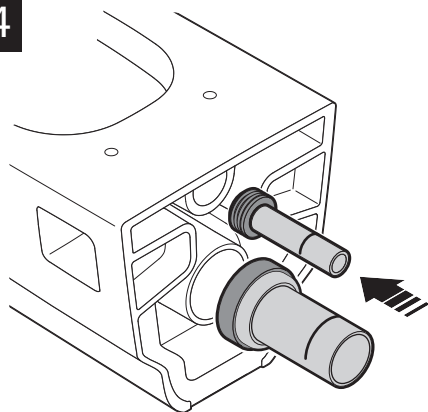

5

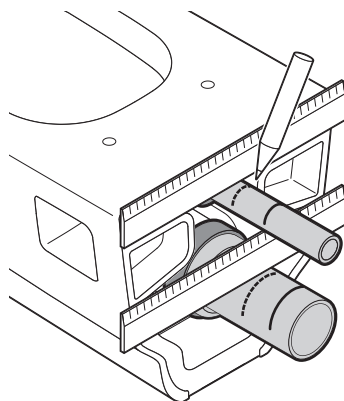

6

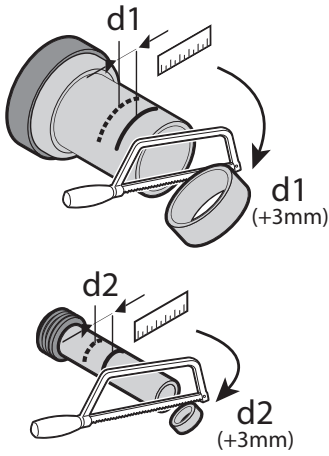

7

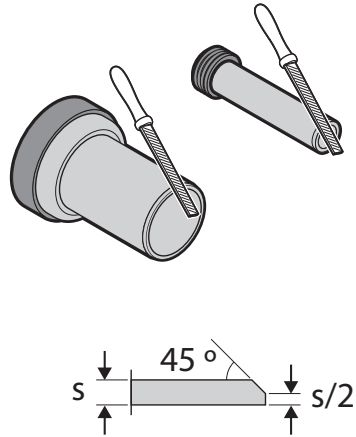

8

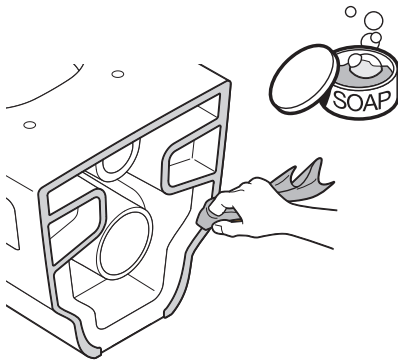

9

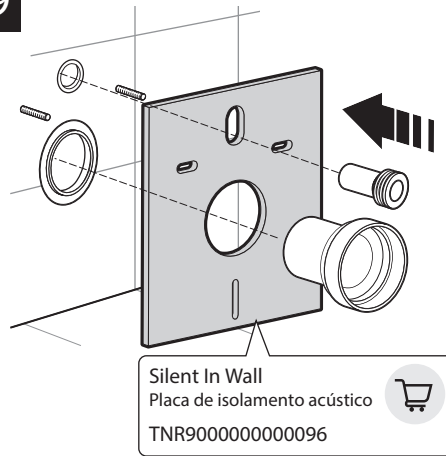

10

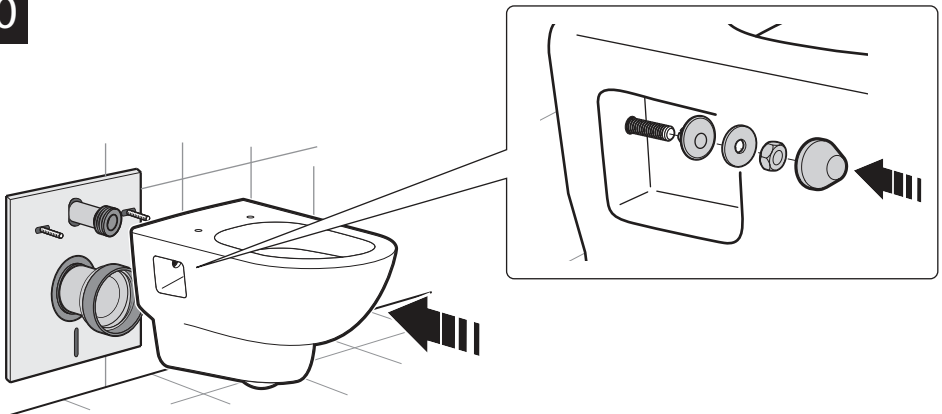



1

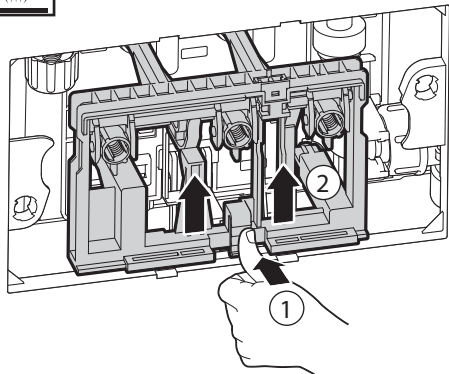

2

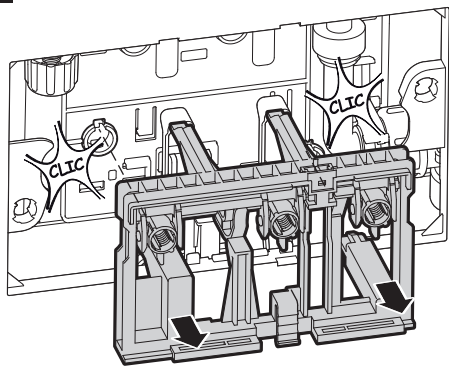

3

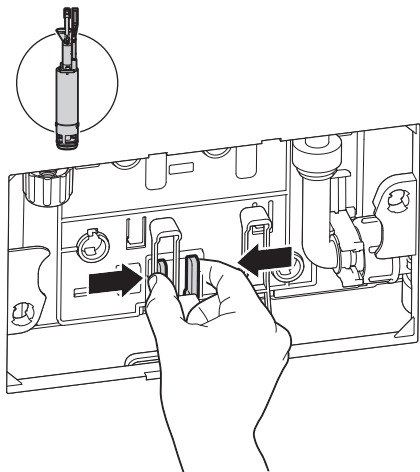

4

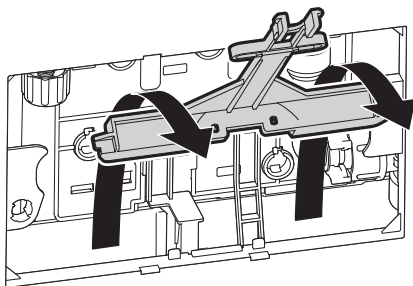

5

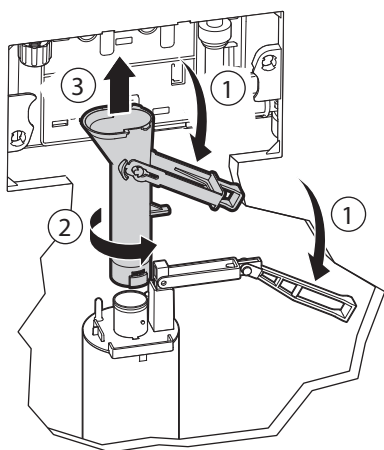

6

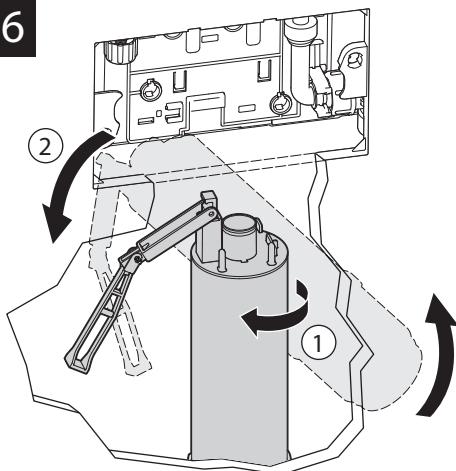

7

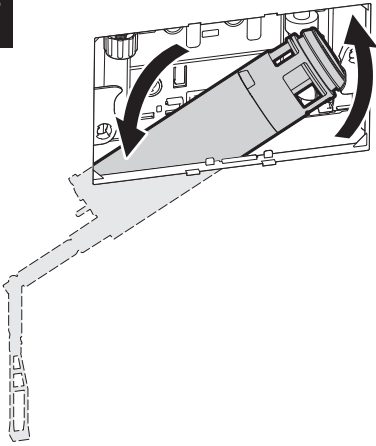

8

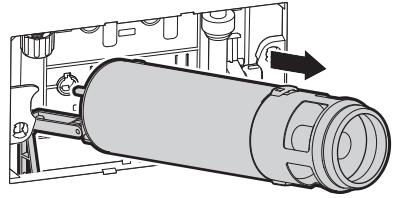

1

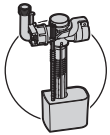

⚠ DO NOT USE
A WRENCH
NÃO UTILIZAR
CHAVE INGLESA

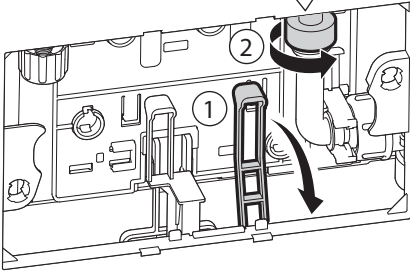
2

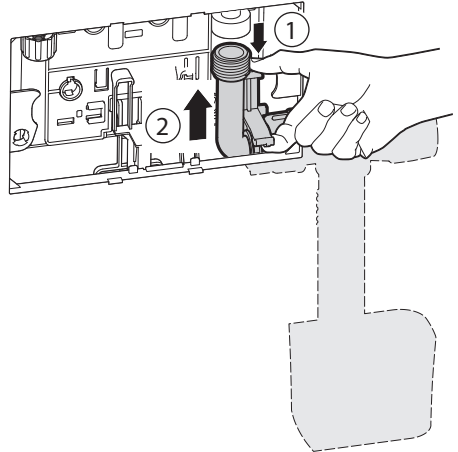

3

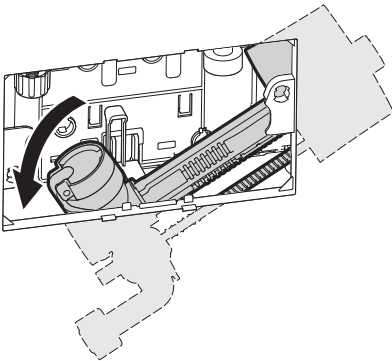

4

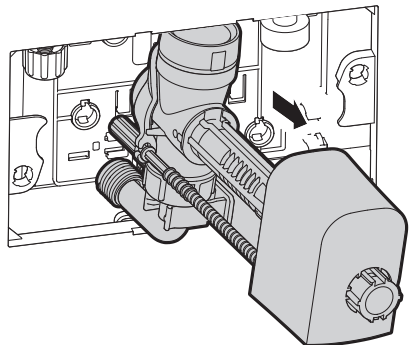

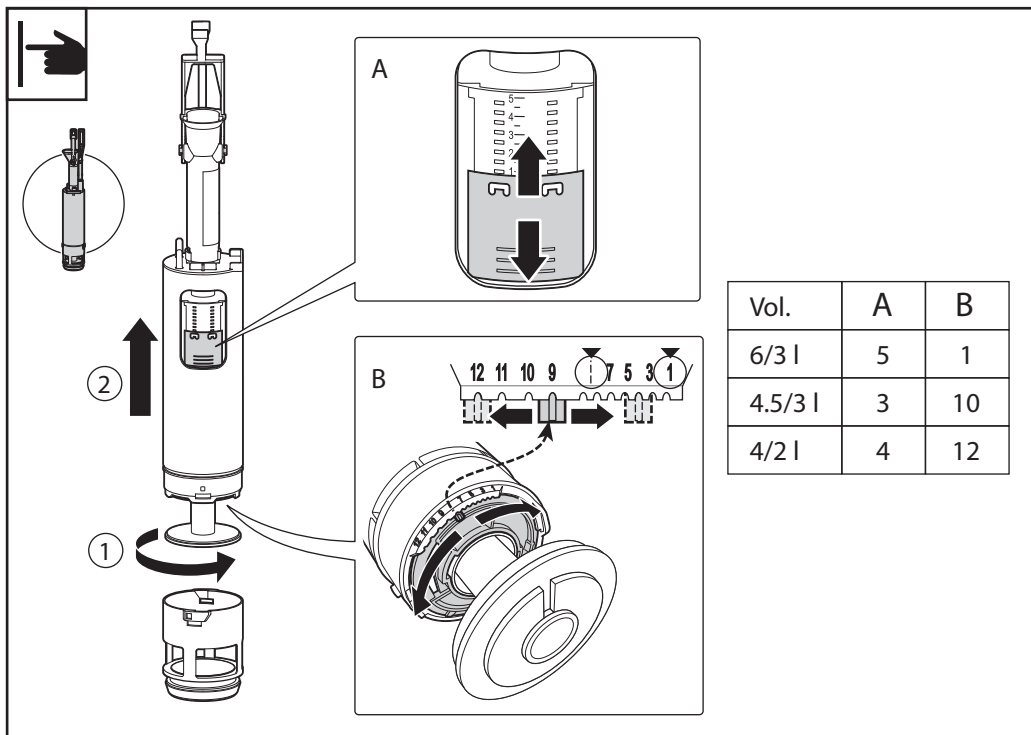

Vol.	A	B
6/3 l	5	1
4.5/3 l	3	10
4/2 l	4	12

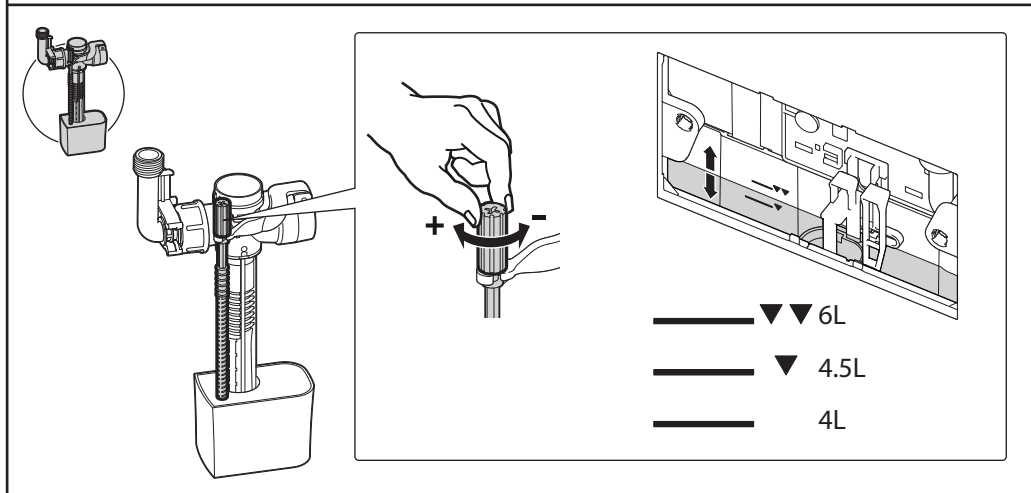

Warranty:
Frame and tank 10 years.
Components 3 years.

Garantia:
Estrutura e tanque 10 anos.
Componentes 3 anos.



As informações e medidas são a título orientativo e susceptíveis de modificações sem aviso prévio. Este documento anula os anteriores.
All information and dimensions should be considered merely approximate and are subject to modification without notice. This document cancels the former ones.
Toutes les dimensions et informations sont à titre indicatif et susceptibles de modifications sans préavis. Ce document annule les précédents.

Esta Empresa respeita a natureza, por isso, todos os nossos manuais são impressos com papéis que ajudam a manter o meio ambiente, utilizando pastas ECF provenientes de florestas renováveis.
This Company respects nature, and therefore all our manuals are printed with papers that help to maintain the environment, using only ECF pulp derived from renewable forests.
Cette société respecte la nature et c'est donc pour cela que tous nos manuels sont imprimés avec du papier qui aide l'environnement, en utilisant seulement les pâtes ECF provenant de bois renouvelables.